

E-flite[®]
ADVANCING ELECTRIC FLIGHT

F4U-4 CORSAIR 1.2M

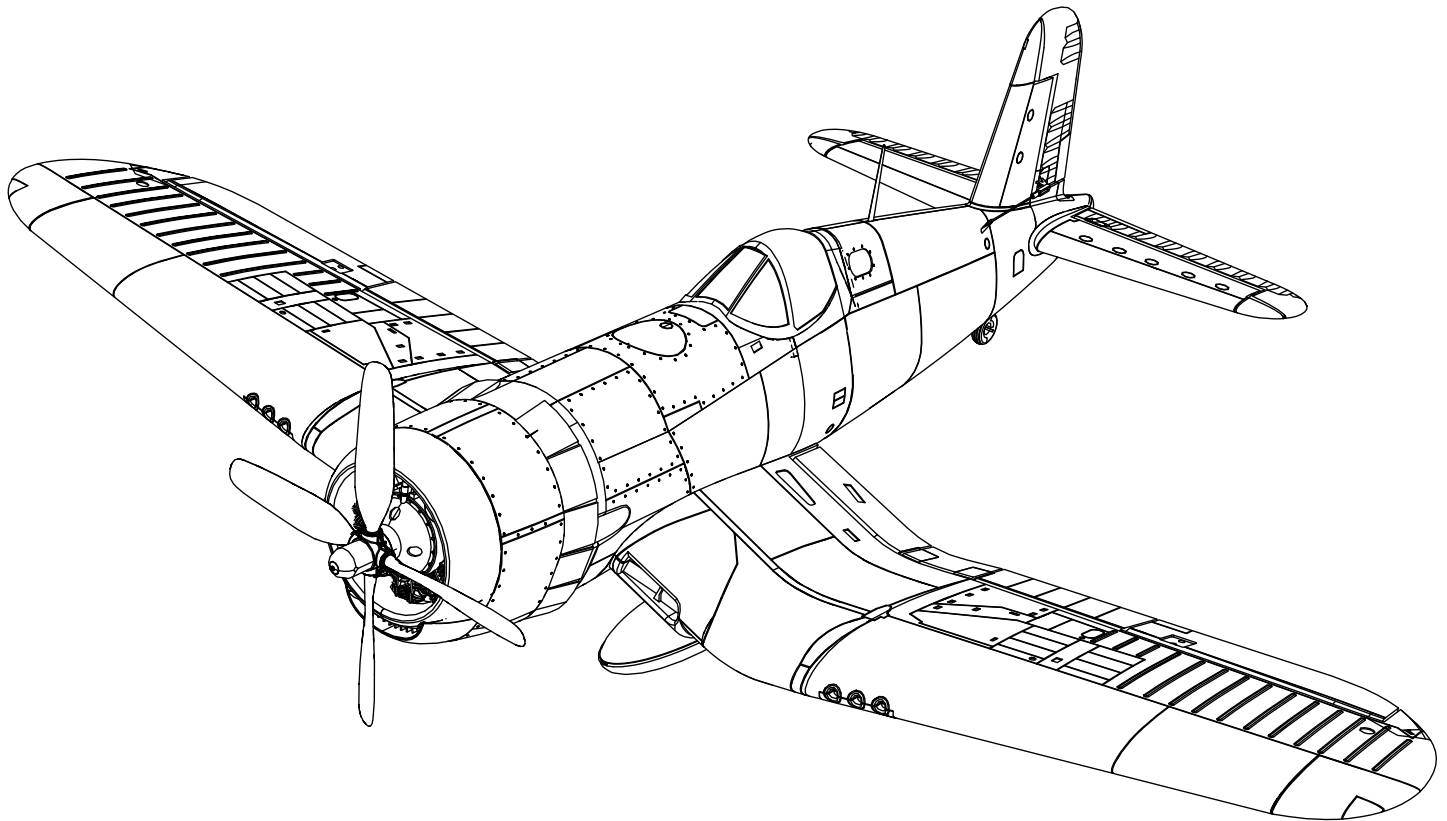

Scan the QR code and select the Manuals and Support quick links from the product page for the most up-to-date manual information.

Scannen Sie den QR-Code und wählen Sie auf der Produktseite die Quicklinks Handbücher und Unterstützung, um die aktuellsten Informationen zu Handbüchern.

Scannez le code QR et sélectionnez les liens rapides Manuals and Support sur la page du produit pour obtenir les informations les plus récentes sur le manuel.

Scannerizzare il codice QR e selezionare i Link veloci Manuali e Supporto dalla pagina del prodotto per le informazioni manuali più aggiornate.



EFL18550



EFL18575

Instruction Manual
Bedienungsanleitung
Manuel d'utilisation
Manuale di Istruzioni

HORIZON[®]
H O B B Y

NOTICE

All instructions, warranties and other collateral documents are subject to change at the sole discretion of Horizon Hobby, LLC. For up-to-date product literature, visit www.horizonhobby.com or towerhobbies.com and click on the support or resources tab for this product.

MEANING OF SPECIAL LANGUAGE

The following terms are used throughout the product literature to indicate various levels of potential harm when operating this product:

WARNING: Procedures, which if not properly followed, create the probability of property damage, collateral damage, and serious injury OR create a high probability of superficial injury.

CAUTION: Procedures, which if not properly followed, create the probability of physical property damage AND a possibility of serious injury.

NOTICE: Procedures, which if not properly followed, create a possibility of physical property damage AND little or no possibility of injury.

 **WARNING:** Read the ENTIRE instruction manual to become familiar with the features of the product before operating. Failure to operate the product correctly can result in damage to the product, personal property and cause serious injury. This is a sophisticated hobby product. It must be operated with caution and common sense and requires some basic mechanical ability. Failure to operate this Product in a safe and responsible manner could result in injury or damage to the product or other property. This product is not intended for use by children without direct adult supervision. Do not use with incompatible components or alter this product in any way outside of the instructions provided by Horizon Hobby, LLC. This manual contains instructions for safety, operation and maintenance. It is essential to read and follow all the instructions and warnings in the manual, prior to assembly, setup or use, in order to operate correctly and avoid damage or serious injury.

14+ AGE RECOMMENDATION: Not for children under 14 years. This is not a toy.

If you own this product, you may be required to register with the FAA. For up-to-date information on how to register with the FAA, please visit <https://registermyuas.faa.gov/>. For additional assistance on regulations and guidance on UAS usage, visit knowbeforeyoufly.org/.

Safety Precautions and Warnings

As the user of this product, you are solely responsible for operating in a manner that does not endanger yourself and others or result in damage to the product or the property of others.

- Always keep a safe distance in all directions around your model to avoid collisions or injury. This model is controlled by a radio signal subject to interference from many sources outside your control. Interference can cause momentary loss of control.
- Always operate your model in open spaces away from full-size vehicles, traffic and people.
- Always carefully follow the directions and warnings for this and any optional support equipment (chargers, rechargeable battery packs, etc.).
- Always keep all chemicals, small parts and anything electrical out of the reach of children.
- Always avoid water exposure to all equipment not specifically designed and protected for this purpose. Moisture causes damage to electronics.
- Never place any portion of the model in your mouth as it could cause serious injury or even death.
- Never operate your model with low transmitter batteries.
- Always keep aircraft in sight and under control.
- Always use fully charged batteries.
- Always keep transmitter powered on while aircraft is powered.
- Always remove batteries before disassembly.
- Always keep moving parts clean.
- Always keep parts dry.
- Always let parts cool after use before touching.
- Always remove batteries after use.
- Always ensure failsafe is properly set before flying.
- Never operate aircraft with damaged wiring.
- Never touch moving parts.

 **WARNING AGAINST COUNTERFEIT PRODUCTS:** If you ever need to replace your Spektrum receiver found in a Horizon Hobby product, always purchase from Horizon Hobby, LLC or a Horizon Hobby authorized dealer to ensure authentic high-quality Spektrum product. Horizon Hobby, LLC disclaims all support and warranty with regards, but not limited to, compatibility and performance of counterfeit products or products claiming compatibility with DSM or Spektrum technology.

Included / Recommended Equipment

	PNP PLUG-N-PLAY	BNF [®] BASIC
Motor: BL15 Brushless Outrunner 850Kv 14 Pole Motor (EFLM4115)	Installed	Installed
ESC: Avian 70A Smart Lite Brushless (SPMXAE70)	Installed	Installed
Servo: Aileron (2), Flap (2), Elevator (1), and Rudder (1) 9 gram servo (SPMSA330)	Installed	Installed
Receiver: Spektrum™ AR631 DSMX 6-Channel AS3X and SAFE Receiver (SPMAR631)	Required to Complete	Installed
Recommended Battery: 14.8v 4S 2200mAh 30C Li-Po (SPM22004S30)	Required to Complete	Required to Complete
Recommended Battery Charger: 3-cell to 4-cell Li-Po Battery Balancing Charger	Required to Complete	Required to Complete
Recommended Transmitter: Full-Range 6 channel (or more) 2.4GHz with Spektrum DSM2 [®] /DSMX [®] technology with adjustable Dual Rates.	Required to Complete	Required to Complete

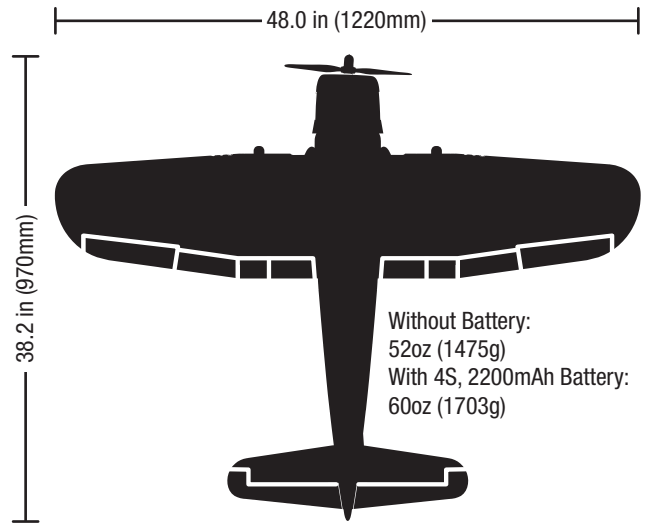

Table of Contents

Transmitter Setup BNF	4	Factory Settings for the Control Horns and Servo Arms	14
Smart Technology and Flight Times	4	Motor Service	14
Receiver Selection and Installation PNP	5	AS3X [®] System Trouble Shooting Guide	14
Assemble the Aircraft	6	Troubleshooting Guide	15
Optional Drop Tank Installation	8	Replacement Parts	16
Center of Gravity (CG)	9	Recommended Parts	16
Control Surface Direction	9	Optional Parts	16
Control Centering	9	Hardware	16
Flight Battery Installation and Electronic Speed Control (ESC) Arming	10	Important Federal Aviation Administration (FAA) Information	17
General Binding Tips and Failsafe BNF	11	AMA National Model Aircraft Safety Code	17
Transmitter and Receiver Binding / Enabling and Disabling SAFE Select BNF	11	Limited Warranty	18
SAFE [®] Select Switch Designation BNF	12	Contact Information	19
Integrated ESC Telemetry	12	FCC Information	19
In Flight Trimming BNF	13	IC Information	19
Flying Tips and Repairs	13	Compliance Information for the European Union	19
Post Flight	13		

Transmitter Setup *BNF*

IMPORTANT: After you set up your model, always rebind the transmitter and receiver to set the desired failsafe positions.

Dual Rates

Make your first flights in low rate. For landings, use high rate elevator.

NOTICE: To ensure AS3X technology functions properly, do not lower rate values below 50%. If less control deflection is desired, manually adjust the position of the pushrods on the servo arm

NOTICE: If oscillation occurs at high speed, refer to the Troubleshooting Guide for more information.

Exponential

After first flights, you may adjust exponential in your transmitter.

† Some of the terminology and function locations used in the iX12 and iX20 programming may be slightly different than other Spektrum AirWare™ radios. The names given in parentheses correspond to the iX12 and iX20 programming terminology. Consult your transmitter manual for specific information about programming your transmitter.

Computerized Transmitter Setup (DX6i, DX6, DX7, DX7S, DX8, DX9, DX10t and DX18)	
Start all transmitter programming with a blank ACRO model (do a model reset), then name the model.	
Set Dual Rates to:	HIGH 100% LOW 70%
Set Servo Travel to:	100%
DX6i	1. Go to the SETUP LIST MENU
	2. Set MODEL TYPE: ACRO
	3. Go to ADJUST LIST MENU
	4. Set FLAPS: Norm ▼100 Flap LAND ▲100 Flap
DX7S DX8	1. Go to the SYSTEM SETUP
	2. Set MODEL TYPE: AIRPLANE
	3. Set WING TYPE: 1 AIL 1 FLAP
	4. Go to the FUNCTION LIST
	5. Set SERVO SETUP: Reverse GEAR
	6. Set FLAP SYSTEM: Choose Flap NORM: -100% FLAP MID: 0% FLAP LAND: 100% FLAP SPEED 2.0S: SWITCH = FLAP
DX6e, DX8e, DX6 G2, DX7 G2, DX8 G2, DX9, DX18, DX20, iX12, iX20, NX6, NX8, NX10	1. Go to the SYSTEM SETUP
	2. Set MODEL TYPE: AIRPLANE
	3. Set AICRAFT TYPE: WING: 1 AIL 1 FLAP
	4. Go to the FUNCTION LIST
	5. Set SERVO SETUP: Reverse GEAR
	6. Set FLAP SYSTEM: SELECT SWITCH D: POS 0: -100% FLAP POS 1: 0% FLAP POS 2: 100% FLAP SPEED 2.0

Smart Technology and Flight Times

When using the recommended 4S 2200mAh battery, the expected flight time is 3–5 minutes. Actual flight times may vary, based on the condition and performance of the particular battery, flying conditions, and throttle management. Flight times will typically be longer when using a lower power setting. Set your flight timer according to your flying style.

When using a compatible Spektrum AirWare equipped transmitter and Smart-technology receiver along with the installed Smart-technology ESC, real-time battery voltage telemetry is available to minimize or eliminate the need for a timer.

See the **Integrated ESC Telemetry** section of this manual for more information.

ESC Status			
RPM:	0		
Volts:	0.0V		
Motor:	0.0A	0% Output	
Throttle:	0%		
Fet Temp:	0.0C		
BEC:	0.0C	0.0A	0.0V

Receiver Selection and Installation *PNP*

The recommended receiver for this aircraft is the Spektrum AR631.

If you choose to install a different receiver, it needs to be a 4-channel or more full range (sport) receiver. Refer to the manual of your chosen receiver for correct installation and operation instructions.

AR631 Installation

1. Lift the rear of the canopy to remove the canopy from the top of the fuselage.
2. Attach the appropriate control surfaces to their respective ports on the receiver using the table at the right.
3. Using double-sided servo tape, mount the receiver to the flat area, as shown. The receiver should be mounted in the orientation shown, parallel to the length of the fuselage, with the label facing up and the servo ports facing the front of the aircraft. The orientation of the receiver is critical for all AS3X® and SAFE® technology setups.



CAUTION: Incorrect installation of the receiver could cause a crash.

ANTENNA INSTALLATION

The AR631 receiver has a coaxial style antenna. We recommend installing the antenna as far as possible from metal, batteries, or carbon fiber to maximize signal reception performance.

NOTICE: Do not cut, kink, or modify the antenna. Damage to the coaxial portion of an antenna will reduce the performance of the antenna. Shortening or cutting off the 31 mm tip will reduce the range.

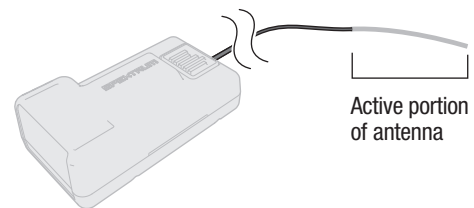
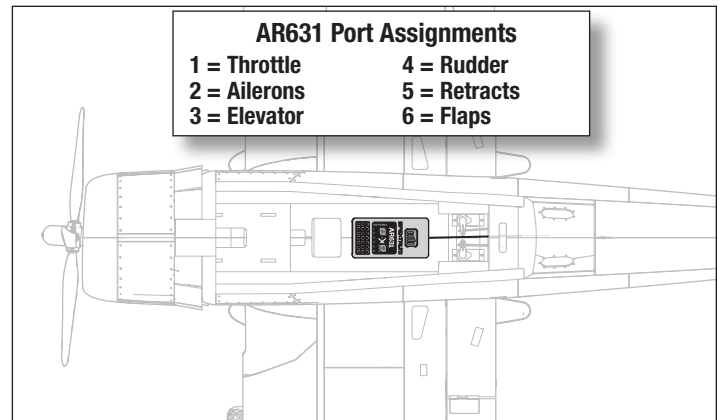

Assemble the Aircraft

Horizontal Tail Installation

1. Slide the horizontal tail (**A**) into the slot in the rear of the fuselage. Ensure the control horn faces down.
2. With a 2mm Allen driver, secure the horizontal tail piece in place using the included M3 x 26 countersunk machine screw (**B**). Use caution to avoid over-tightening the screw.
3. Attach the clevis to the elevator control horn (see instructions for clevis connection).

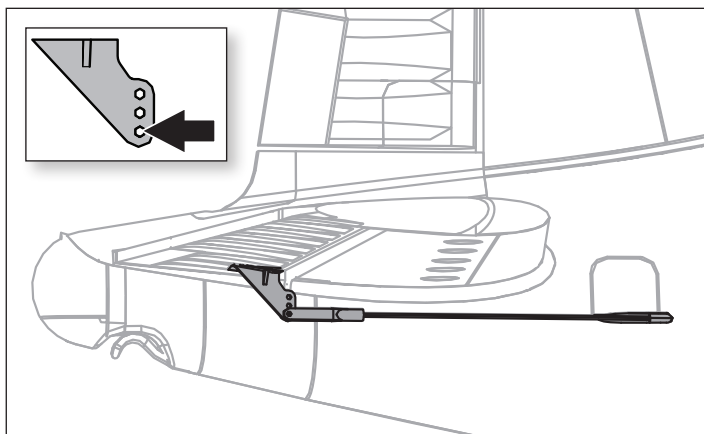
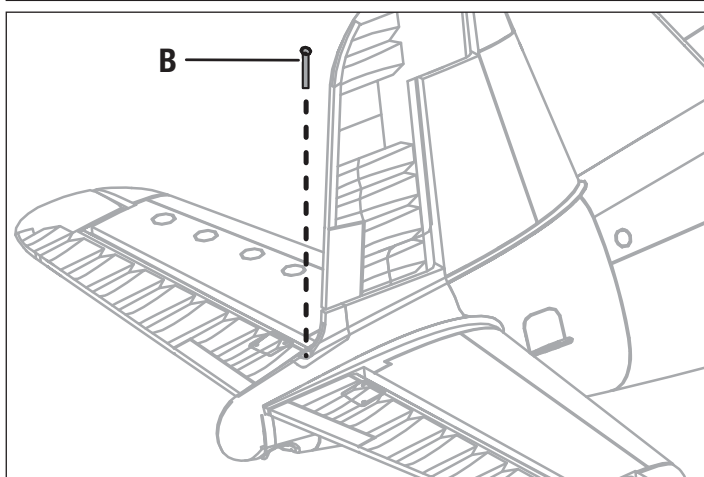
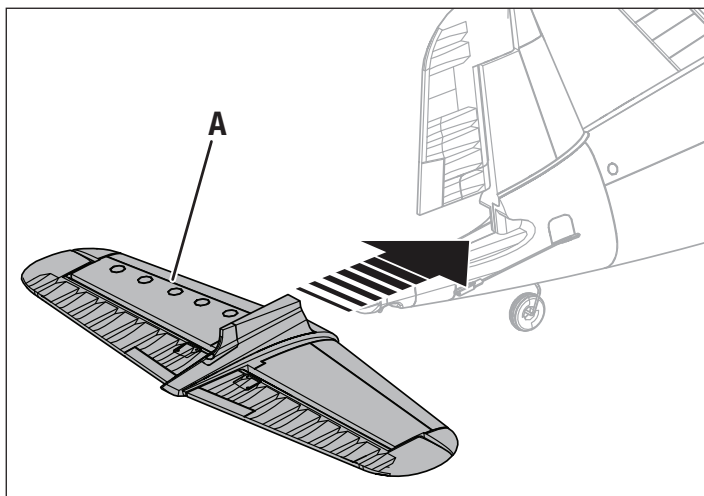

Clevis Installation

1. Slide the retaining tube off the clevis body.
2. Carefully spread the clevis.
3. Insert clevis pin into control horn.
4. Slide the retaining tube into position on the clevis body.

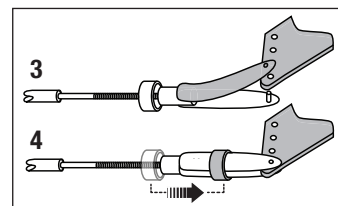
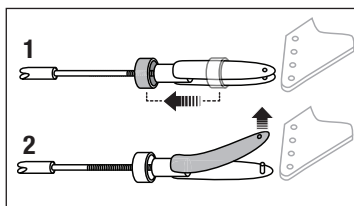

Assemble the Aircraft

Wing Installation

1. Remove the canopy hatch.
2. Guide the flap, retract and aileron servo connectors (A) through the hole (B) located in the bottom of the fuselage as shown.

TIP: If needed, use hemostats or pliers to pull the servo connectors into the fuselage.

3. Plug in the Y-harnesses into the receiver. The single connector side of the Y-harnesses are marked Ail, Gear, and Flap.

IMPORTANT: The ailerons must be connected to the receiver's AILE (CH 2) with a Y-harness (included) for the AS3X® system to function properly.

4. Align the wing with the fuselage, and use a 2mm Allen driver to secure it into position with the included 4 M3 x 26 countersunk machine screws (C).

CAUTION: DO NOT crush or otherwise damage the wiring when attaching the wing to the fuselage.

5. Reinstall the canopy hatch on the fuselage.

Disassemble in reverse order.

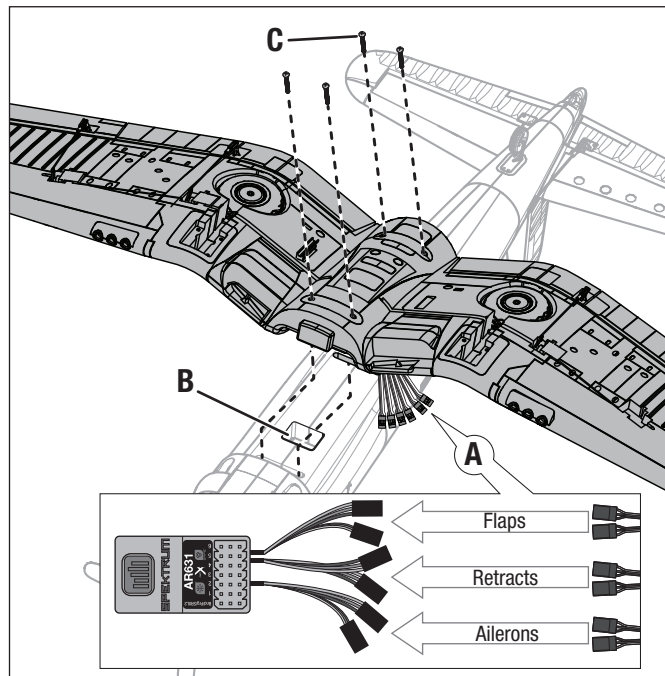
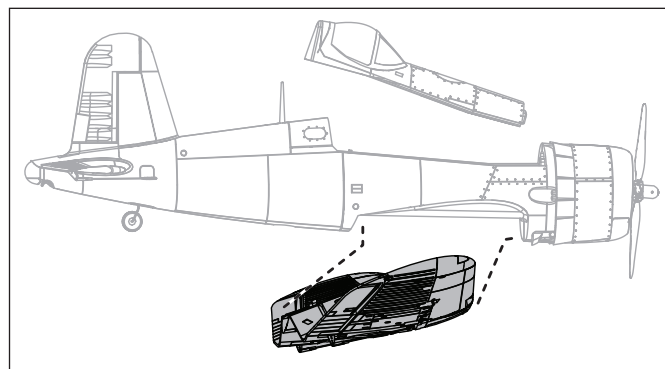

Assemble the Aircraft

Propeller Installation

IMPORTANT: Install the propeller after all system setups are complete to reduce the chance of accidental injury.

1. Install back side of propeller hub (A), propeller (B), and front side propeller hub (C) onto the motor shaft (D). The propeller size numbers (10.5 x 8) must face forward for correct propeller operation.
2. Install the spinner nut (E) to secure the propeller into place. Use a small screw driver or hex wrench inserted into the small hole (Inset) and turn clockwise to secure it into place.

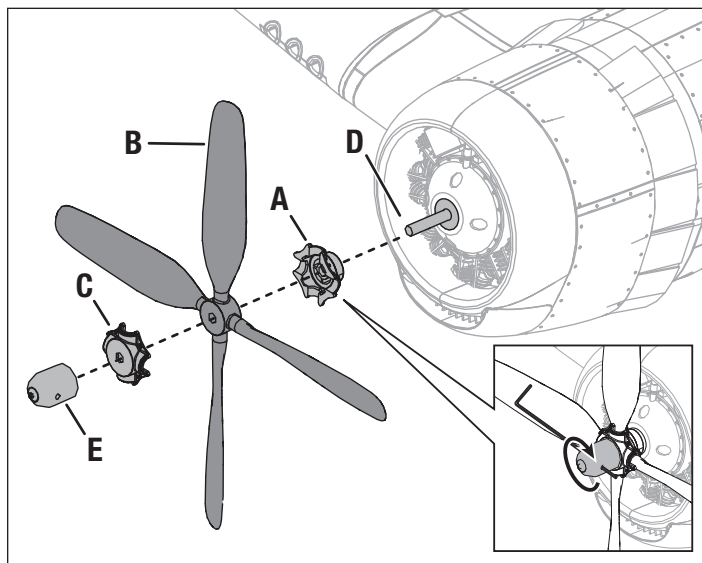

Optional Drop Tank Installation

Slide the optional drop tanks (A) into the rails (B) on each wing. Check the Center of Gravity with the drop tanks installed. See *Adjusting the Center of Gravity* for more information.

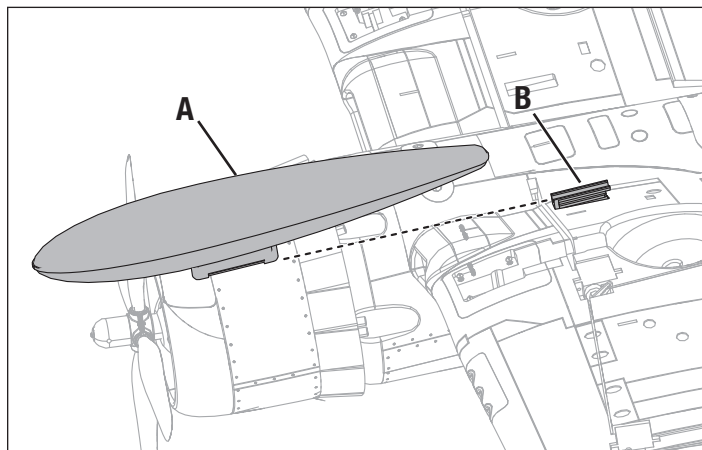

Center of Gravity (CG)

After installing the battery (in the recommended position) and before powering on the ESC, verify the CG. The CG location starting point is 73mm (range: $73\text{mm} \pm 3\text{mm}$) behind the leading edge, as shown.

3S 2200mAh Smart battery CG position – The battery is installed all the way forward in battery compartment. Only the front battery strap will be used.

4S 3200mAh Smart battery CG position – The battery is installed centered in the battery tray, using both front and rear battery straps.

Balance the aircraft inverted on your fingertips adjacent to the fuselage under the wings.

- If the nose goes down, move the flight battery back until the aircraft balances.
- If the nose goes up, move the flight battery forward until the aircraft balances.

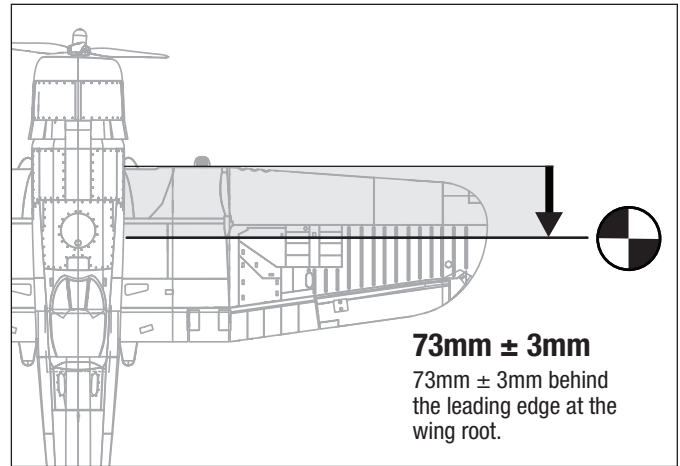

Control Surface Direction

Switch on the transmitter and connect the battery. Use the transmitter to operate the aileron, elevator, and rudder controls. View the aircraft from the rear when checking the control directions.

NOTICE: Bind the aircraft and transmitter before performing these tests. Move the transmitter controls to make sure the aircraft control surfaces move correctly and in the proper direction. Make sure the tail linkages move freely.

Elevators

1. Pull the elevator stick back. The elevator should move up, which will cause the aircraft to pitch up.
2. Push the elevator stick forward. The elevator should move down, which will cause the aircraft to pitch down.

Ailerons

3. Move the aileron stick to the left. The left aileron should move up and the right aileron should move down, which will cause the aircraft to bank left.
4. Move the aileron stick to the right. The right aileron should move up and the left aileron down, which will cause the aircraft to bank right.

Rudder

5. Move the rudder stick to the left. The rudder should move to the left, which will cause the aircraft to yaw left.
6. Move the rudder stick to the right. The rudder should move to the right, which will cause the aircraft to yaw right.

	Transmitter Command	Control Surface Response
Elevator		
Aileron		
Rudder		

Control Centering

After assembly and transmitter setup, confirm that the control surfaces are centered. If the control surfaces are not centered, mechanically center the control surfaces by adjusting the linkages.

If adjustment is required, turn the clevis on the linkage to change the length of the linkage between the servo arm and the control horn.

After binding a transmitter to the aircraft receiver, set the trims and sub-trims to 0, then adjust the clevises to center the control surfaces.

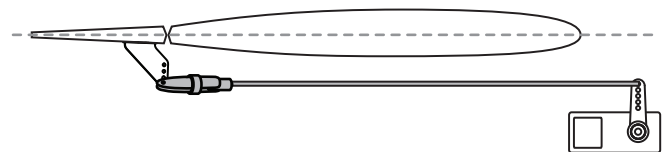

Flight Battery Installation and Electronic Speed Control (ESC) Arming

Battery Selection

We recommend the Spektrum™ 2200mAh 14.8V 4S 30C Li-Po battery (SP-MX22004S30). Refer to the Optional Parts List for other recommended batteries. If using a battery other than those listed, the battery should be within the range of capacity, dimensions and weight of the Spektrum Li-Po battery packs to fit in the fuselage. Be sure the model balances at the recommended CG.

1. Lower the throttle and throttle trim to the lowest settings. Power on the Transmitter, then wait 5 seconds.
2. Carefully lift the back of the canopy hatch (A) to remove.
3. For added security, apply the loop side (soft side) of the optional hook and loop tape (B) to the bottom of your battery, and the hook side to the battery tray.
4. Install the fully charged battery (C) all the way to the front of the battery compartment as shown. Secure using the hook and loop straps (D).
5. Connect the battery to the ESC (the ESC is now armed).
6. Keep the aircraft immobile and away from wind or the system will not initialize.
 - The ESC will sound a series of tones (refer to the binding instructions for more information).
 - An LED will light on the receiver.

If the ESC sounds a continuous double beep after the flight battery is connected, recharge or replace the battery.

7. Reinstall the canopy hatch.

CAUTION: Always keep hands away from the propeller. After initialization, the motor will turn the propeller in response to any throttle movement.

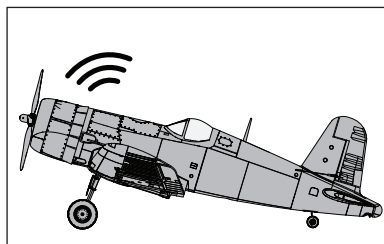
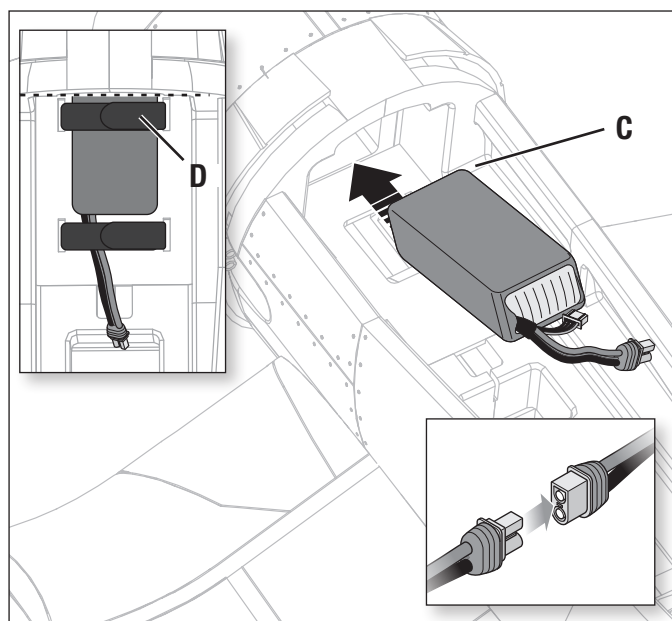
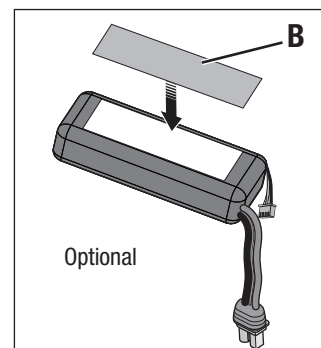
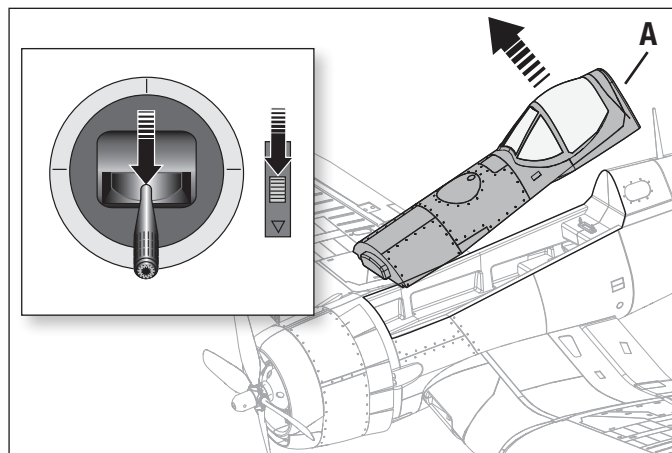

General Binding Tips and Failsafe *BNF*

- The included receiver has been specifically programmed for operation of this aircraft. Refer to the receiver manual for correct setup if the receiver is replaced.
- Keep away from large metal objects while binding.
- Do not point the transmitter's antenna directly at the receiver while binding.
- The orange LED on the receiver will flash rapidly when the receiver enters bind mode.
- Once bound, the receiver will retain its bind settings for that transmitter until you re-bind.
- If the receiver loses transmitter communication, the failsafe will activate. Failsafe moves the throttle channel to low throttle. Pitch and roll channels move to actively stabilize the aircraft in a descending turn.
- If problems occur, refer to the troubleshooting guide or if needed, contact the appropriate Horizon Product Support office.

Transmitter and Receiver Binding / Enabling and Disabling SAFE Select *BNF*

The BNF Basic version of this airplane includes SAFE Select technology, enabling you to choose the level of flight protection. SAFE mode includes angle limits and automatic self leveling. AS3X mode provides the pilot with a direct response to the control sticks. SAFE Select is enabled or disabled during the bind process. With SAFE Select disabled the aircraft is always in AS3X mode. With SAFE Select enabled the aircraft will be in SAFE Select mode all the time, or you can assign a switch to toggle between SAFE Select and AS3X modes.

Thanks to SAFE Select technology, this aircraft can be configured for full-time SAFE mode, full-time AS3X mode, or mode selection can be assigned to a switch.

IMPORTANT: Before binding, read the transmitter setup section in this manual and complete the transmitter setup table to ensure your transmitter is properly programmed for this aircraft.

IMPORTANT: Move the transmitter flight controls (rudder, elevators, and ailerons) and the throttle trim to neutral. Move the throttle to low before and during binding. This process defines the failsafe settings.

You can use either the bind button on the receiver case or the conventional bind plug to complete the binding and SAFE Select process.

SAFE Select can also be activated via Forward Programming in compatible transmitters.

Using The Bind Button...

To Enable SAFE Select

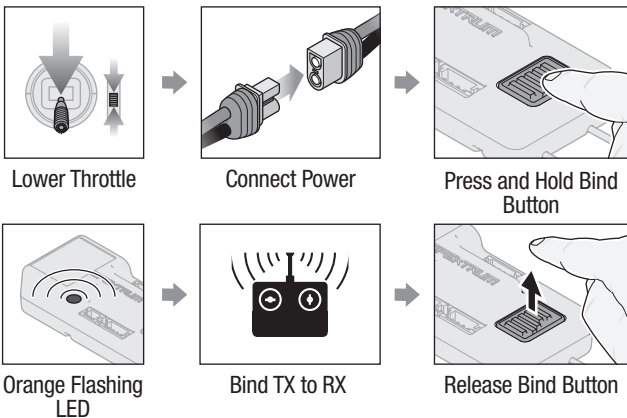

SAFE SELECT ENABLED: The control surfaces cycle back and forth **twice** with a slight pause at neutral every time the receiver is powered on.

To Disable SAFE Select

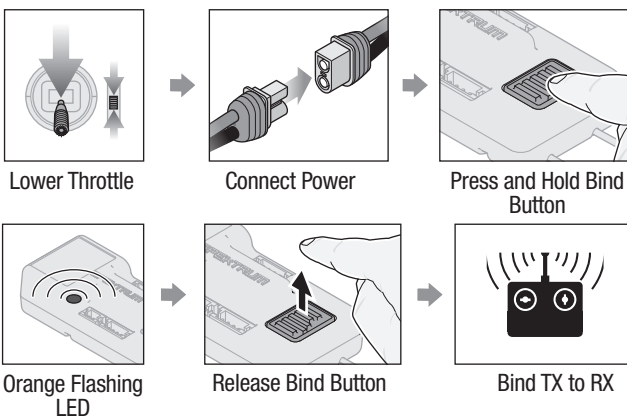

SAFE SELECT DISABLED: The control surfaces cycle back and forth **once** every time the receiver is powered on.

Using The Bind Plug...

To Enable SAFE Select

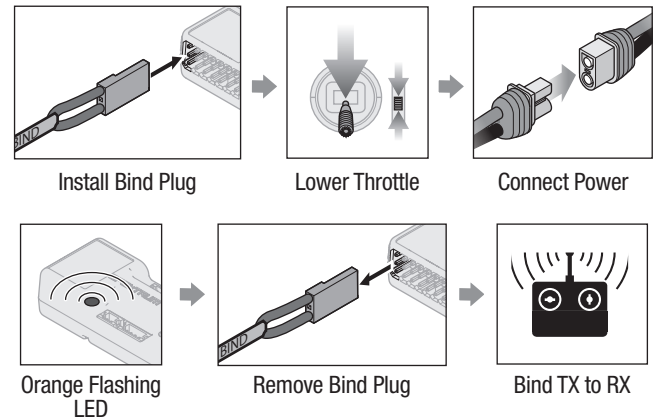

SAFE SELECT ENABLED: The control surfaces cycle back and forth **twice** with a slight pause at neutral every time the receiver is powered on.

To Disable SAFE Select

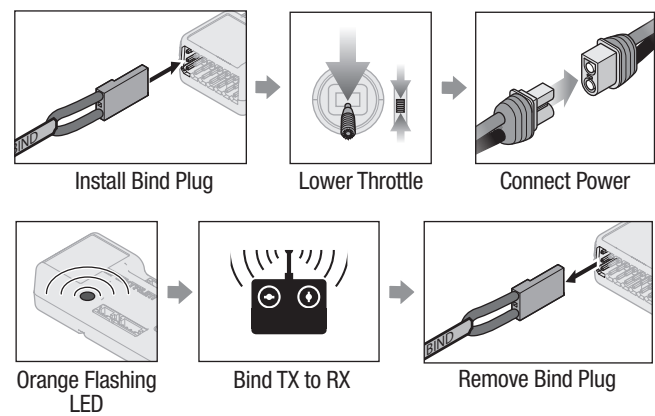

SAFE SELECT DISABLED: The control surfaces cycle back and forth **once** every time the receiver is powered on.

SAFE® Select Switch Designation BNF

Once SAFE Select is enabled, you can choose to fly in SAFE mode full-time, or assign a switch. Any switch on any channel between 5 and 9 can be used on your transmitter.

If the aircraft is bound with SAFE Select disabled, the aircraft will be in AS3X mode exclusively.

CAUTION: Keep all body parts well clear of the propeller and keep the aircraft securely restrained in case of accidental throttle activation.

IMPORTANT: To be able to assign a switch, first verify:

- The aircraft was bound with SAFE Select enabled.
- Your choice for the SAFE Select switch is assigned to a channel between 5 and 9 (Gear, Aux1-4), and travel is set at 100% in each direction.
- The aileron, elevator, rudder and throttle direction are set to normal, not reverse.
- The aileron, elevator, rudder and throttle are set to 100% travel. If dual rates are in use, the switches need to be in the 100% position.

See your transmitter manual for more information about assigning a switch to a channel.

Assigning a Switch

1. Power on the transmitter.
2. Power on the aircraft.
3. Hold both transmitter sticks to the inside bottom corners, and toggle the desired switch 5 times quickly (1 toggle = full up and down).
4. The control surfaces of the aircraft will move, indicating the switch has been selected.

Repeat the process to assign a different switch or to deactivate the current switch.

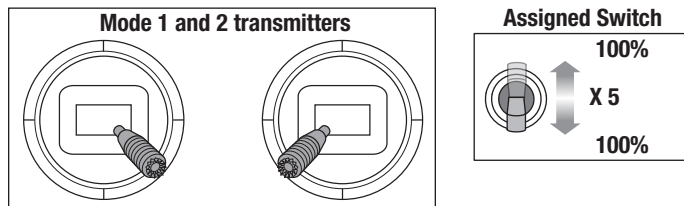

TIP: Use the channel monitor to verify channel movement.*

* This example of the channel monitor shows the stick positions for assigning a switch, the switch selection on Aux2, and +/- 100% travel on the switch.

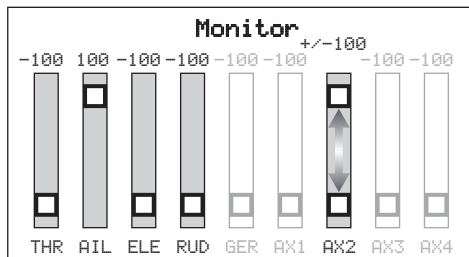

Forward Programming

Assign the SAFE Select channel through forward programming on your compatible Spektrum transmitter.

Forward Programming SAFE Select Setup	
DX series, NX series, iX series	1. Begin with the transmitter bound to the receiver.
	2. Power ON the transmitter.
	3. Assign a switch for SAFE Select that is not already in use for another function. Use any open channel between 5 and 9 (Gear, Aux1-4).
	4. Set switch H (throttle cut) to prevent accidental motor operation.
	5. Power ON the aircraft. A signal bar appears on your transmitter's main screen when the telemetry information is being received.
	6. Go to the FUNCTION LIST (Model Setup)
	7. Select Forward Programming; Select Gyro Settings; Choose SAFE Select to enter the menu.
	8. Set SAFE Select Ch: To the channel you have chosen for SAFE Select.
	9. Set AS3X and SAFE On or Off as desired for each switch position.

For more information about setting SAFE Select and using Forward Programming, please refer to the following link for a detailed video:

<https://www.youtube.com/watch?v=o-46P066cik>



Integrated ESC Telemetry

BNF: This aircraft includes telemetry between the ESC and receiver, which can provide information including RPM, voltage, motor current, throttle setting (%), and FET (speed controller) temperature.

PNP: The ESC in this aircraft is capable of delivering telemetry information over the throttle connection when paired with a Smart technology-compatible Spektrum telemetry receiver. It will function with a normal PWM servo signal for common radio control systems.

For more information about compatible transmitters, firmware updates, and how to use the telemetry technology on your transmitter, visit www.SpektrumRC.com.

Telemetry Setup	
DX series, NX series, iX series	1. Begin with the transmitter bound to the receiver.
	2. Power ON the transmitter.
	3. Set switch H (throttle cut) to prevent accidental motor operation.
	4. Power ON the aircraft. A signal bar appears on your transmitter's main screen when the telemetry information is being received.
	5. Go to the FUNCTION LIST (Model Setup)
	6. Select TELEMETRY; Smart ESC
	7. Set Total Cells: 3 or 4 cells, depending on the battery
	8. Set LVC Alarm: 3.4V Set Alarm; Voice/Vibe
	9. Set pole count: 14 pole

In Flight Trimming *BNF*

During your first flight, trim the aircraft for your flying style in AS3X flight mode. Flight trim is usually performed between 70–100% power setting, per your preference. Make small trim adjustments with your transmitter's trim switches to straighten the aircraft's flight path.

After adjusting the trim, do not touch the control sticks for 3 seconds. This allows the receiver to learn the correct settings to optimize AS3X performance.

Failure to do so could affect flight performance.

3 Seconds

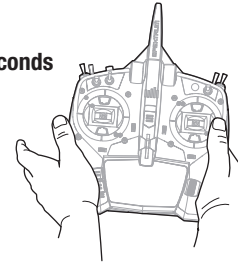

Flying Tips and Repairs

Consult local laws and ordinances before choosing a flying location.

Range Check your Radio System

Before you fly, range check the radio system. Refer to your specific transmitter instruction manual for range test information.

Oscillation

Once the AS3X system is active (after advancing the throttle past 25% for the first time), the control surfaces react to aircraft movement. In some flight conditions you may see oscillation about an axis. If oscillation occurs, refer to the Troubleshooting Guide for more information.

Takeoff

Place the aircraft facing into the wind. Set the transmitter in low rate, and use the flaps switch to drop the flaps to the half, or partial flap position. Gradually increase the throttle to $\frac{3}{4}$, and steer with the rudder. **Flaps make takeoffs shorter.** As the tail comes off the ground, pull back gently on the elevator. When the aircraft is airborne, flip the gear switch to raise the landing gear. Climb to a comfortable altitude, and then flip the flaps switch to raise the flaps.

Flying

For your first flight with the recommended battery pack (SPMX22004S30). Set the transmitter timer or monitor the flight battery voltage telemetry as described in the **Smart Technology and Flight Times** section. If at any time the motor pulses, land the aircraft immediately to recharge the flight battery. See the **Low Voltage Cutoff (LVC)** section for details on maximizing battery health and run time.

Landing

Land the aircraft into the wind. Use high rate elevator for landings. Use a small amount of throttle for the entire descent. Lower the throttle to $\frac{1}{4}$ and flip the flaps switch to deploy the flaps to the appropriate position, usually full down. **Flaps will make the landing approach steeper and slower, and allow for a smoother landing.** Flip the gear switch to lower the landing gear. This will slow the aircraft further.

Keep the throttle on until the aircraft is ready to flare. During flare, keep the wings level and the aircraft pointed into the wind. Gently lower the throttle while pulling back on the elevator to bring the aircraft down on its wheels.

When landing on grass, hold full up elevator after touchdown and when taxiing to prevent nosing over.

Once on the ground, avoid sharp turns until the plane has slowed enough to prevent scraping the wingtips.

Post Flight

1	Disconnect the flight battery from the ESC (Required for Safety and battery life).
2	Power OFF the transmitter.
3	Remove the flight battery from the aircraft.
4	Recharge the flight battery.

NOTICE: If a crash is imminent, reduce the throttle. Failure to do so could result in extra damage to the airframe, as well as damage to the ESC and motor.

NOTICE: After any impact, always ensure the receiver is secure in the fuselage. If you replace the receiver, install the new receiver in the same orientation as the original receiver or damage may result.

NOTICE: Crash damage is not covered under warranty.

NOTICE: When you are finished flying, never leave the aircraft in direct sunlight or in a hot, enclosed area such as a car. Doing so can damage the aircraft.

Low Voltage Cutoff (LVC)

When a Li-Po battery is discharged below 3V per cell, it will not hold a charge. The ESC protects the flight battery from over-discharge using Low Voltage Cutoff (LVC). Before the battery charge decreases too much, LVC removes power supplied to the motor. Power to the motor pulses, showing that some battery power is reserved for flight control and safe landing.

Disconnect and remove the Li-Po battery from the aircraft after use to prevent trickle discharge. Charge the Li-Po battery to about half capacity before storage. During storage, make sure the battery charge does not fall below 3V per cell. LVC does not prevent the battery from over-discharge during storage.

NOTICE: Repeated flying to LVC will damage the battery.

Tip: Monitor your aircraft battery's voltage before and after flying by using a Li-Po Battery Voltage Checker (SPMXBC100, sold separately).

Repairs

Thanks to the EPO material in this aircraft, repairs to the foam can be made using virtually any adhesive (hot glue, regular CA, epoxy, etc). When parts are not repairable, see the Replacement Parts List for ordering by item number. For a listing of all replacement and optional parts, refer to the list at the end of this manual.

NOTICE: Use of CA accelerant on your aircraft can damage paint. DO NOT handle the aircraft until accelerant fully dries.

5	Repair or replace all damaged parts.
6	Store the flight battery apart from the aircraft and monitor the battery charge.
7	Make note of the flight conditions and flight plan results, planning for future flights.

Factory Settings for the Control Horns and Servo Arms

The table to the right shows the factory settings for the control horns and servo arms. Fly the aircraft at factory settings before making changes.

	Horns	Arms
Elevator		
Ailerons		
Flaps		
Rudder		

Motor Service

CAUTION: Always disconnect the flight battery before performing motor service.

Disassembly

1. Remove the spinner nut (A) from the motor shaft (B). Loosen the spinner nut by using a small screw driver or hex wrench inserted into the small hole.
2. Remove the front hub (C), propeller (D) and back hub (E) from the motor shaft.
3. Using a Phillips screwdriver, remove the four (4) 2 x 8mm self tapping screws (F) and the dummy motor (G) from the fuselage.
4. Using a Phillips screwdriver, remove the four (4) 2.6 x 15mm self tapping screws (H) and the motor (I) with the X-mount from the fuselage.
5. Disconnect the motor wires from the ESC wires.
6. Using a Phillips screwdriver, remove the four (4) M3 x 6 countersunk machine screws (J) and motor from the X-mount (K).

Assembly

Assemble in reverse order.

- Correctly align and connect the motor wire colors with the ESC wires.
- Install the propeller with the size numbers (10.5 x 8) facing forward.
- Tighten the spinner nut to secure the propeller into place.

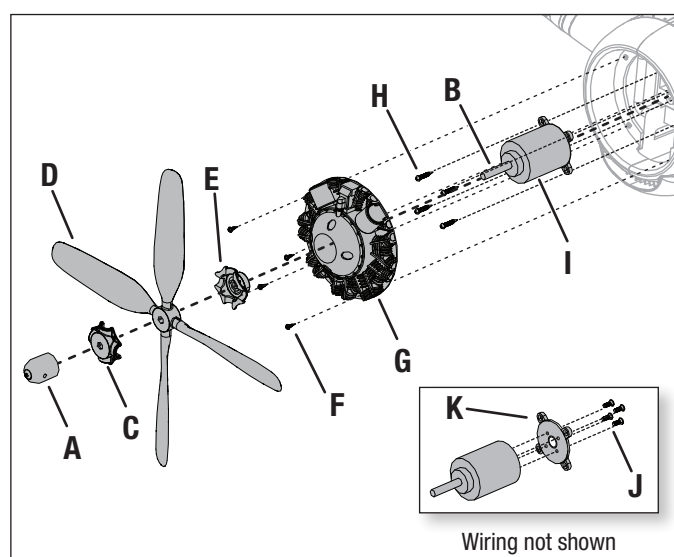

AS3X® System Trouble Shooting Guide

Problem	Possible Cause	Solution
Oscillation	Damaged propeller or spinner	Replace propeller or spinner
	Imbalanced propeller	Balance the propeller. For more information, view John Redman's propeller balancing video at www.horizonhobby.com
	Motor vibration	Replace parts or correctly align all parts and tighten fasteners as needed
	Loose receiver	Align and secure receiver in fuselage
	Loose aircraft controls	Tighten or otherwise secure parts (servo, arm, linkage, horn and control surface)
	Worn parts	Replace worn parts (especially propeller, spinner or servo)
	Irregular servo movement	Replace servo
Inconsistent flight performance	Trim is not at neutral	If you adjust trim more than 8 clicks, adjust the clevis to remove trim
	Sub-Trim is not at neutral	No Sub-Trim is allowed. Adjust the servo linkage
	Aircraft was not kept immobile for 5 seconds after battery connection	With the throttle stick in lowest position. Disconnect battery, then reconnect battery and keep the aircraft still for 5 seconds
Incorrect response to the AS3X Control Direction Test	Incorrect direction settings in the receiver, which can cause a crash	DO NOT fly. Correct the direction settings (refer to the receiver manual), then fly

Troubleshooting Guide

Problem	Possible Cause	Solution
Aircraft will not respond to throttle but responds to other controls	Throttle not at idle and/or throttle trim too high	Reset controls with throttle stick and throttle trim at lowest setting
	Throttle servo travel is lower than 100%	Make sure throttle servo travel is 100% or greater
	Throttle channel is reversed	Reverse throttle channel on transmitter
	Motor disconnected from ESC	Make sure motor is connected to the ESC
Extra propeller noise or extra vibration	Damaged propeller and spinner, collet or motor	Replace damaged parts
	Propeller is out of balance	Balance or replace propeller
	Prop nut is too loose	Tighten the prop nut
Reduced flight time or aircraft under-powered	Flight battery charge is low	Completely recharge flight battery
	Propeller installed backwards	Install propeller with numbers facing forward
	Flight battery damaged	Replace flight battery and follow flight battery instructions
	Flight conditions may be too cold	Make sure battery is warm before use
Aircraft will not Bind (during binding) to transmitter	Battery capacity too low for flight conditions	Replace battery or use a larger capacity battery
	Transmitter too near aircraft during binding process	Move powered transmitter a few feet from aircraft, disconnect and reconnect flight battery to aircraft
	Aircraft or transmitter is too close to large metal object, wireless source or another transmitter	Move aircraft and transmitter to another location and attempt binding again
	The bind plug is not installed correctly in the bind port	Install bind plug in bind port and bind the aircraft to the transmitter
	Flight battery/transmitter battery charge is too low	Replace/recharge batteries
Aircraft will not connect (after binding) to transmitter	Bind switch or button not held long enough during bind process	Power off transmitter and repeat bind process. Hold transmitter bind button or switch until receiver is bound
	Transmitter too near aircraft during connecting process	Move powered transmitter a few feet from aircraft, disconnect and reconnect flight battery to aircraft
	Aircraft or transmitter is too close to large metal object, wireless source or another transmitter	Move aircraft and transmitter to another location and attempt connecting again
	Bind plug left installed in bind port	Rebind transmitter to the aircraft & remove the bind plug before cycling power
	Aircraft bound to different model memory (ModelMatch™ radios only)	Select correct model memory on transmitter
	Flight battery/Transmitter battery charge is too low	Replace/recharge batteries
Control surface does not move	Transmitter may have been bound to a different aircraft using different DSM protocol	Bind aircraft to transmitter
	Control surface, control horn, linkage or servo damage	Replace or repair damaged parts and adjust controls
	Wire damaged or connections loose	Do a check of wires and connections, connect or replace as needed
	Transmitter is not bound correctly or the incorrect airplanes was selected	Re-bind or select correct airplanes in transmitter
	Flight battery charge is low	Fully recharge flight battery
Controls reversed	BEC (Battery Elimination Circuit) of the ESC is damaged	Replace ESC
	Transmitter settings are reversed	Perform the Control Direction Test and adjust the controls on transmitter appropriately
Motor power pulses then motor loses power	ESC uses default soft Low Voltage Cutoff (LVC)	Recharge flight battery or replace battery that is no longer performing
	Weather conditions might be too cold	Postpone flight until weather is warmer
	Battery is old, worn out, or damaged	Replace battery
	Battery C rating might be too small	Use recommended battery

Replacement Parts

Part #	Description
EFL1228	Motor X-Mount
EFL18501	Fuselage with Hatch
EFL18502	Wing: F4U-4 1.2m
EFL18506	Decal Sheet: F4U-4 1.2m
EFL8503	Horizontal Stabilizer: F4U-4 1.2m
EFL8504	Hatch with Pilot: F4U-4 1.2m
EFL8505	Pushrod Set
EFL8507	Prop Adapter with Hub
EFL8508	Hardware Set
EFL8509	Drop Tank
EFL8510	Servo Tape
EFL8511	Landing Gear Parts
EFL8512	Wheel Set
EFLG1590R	90 Degree Rotating Retract Pair
EFLM4115	BL15 Brushless Outrunner 850kV
EFLP105084BL	Propeller, 4 Blade, 10.5x8
SPMAR631	AR631 DSMX 6-Channel AS3X & SAFE Receiver
SPMSA330	A330 9g Sub-Micro Servo
SPMXAE1070B	Avian Smart Lite 70A Brushless ESC, 3S-6S IC3

Recommended Parts

Part #	Description
SPMR6775	NX6 6 CH DSMX Transmitter Only
SPMX22004S30	14.8V 2200mAh 4S 30C Smart LiPo Battery: IC3
SPMXC1080	Spektrum Smart S1100 AC Charger 1x100W

Optional Parts

Part #	Description
SPMR8200	NX8 8 Ch DSMX Transmitter Only
SPMX22004S50	14.8V 2200mAh 4S 50C Smart LiPo Battery: IC3
SPMX224S50	14.8V 2200mAh 4S 50C Smart G2 LiPo Battery: IC3
SPMX32003S30	11.1V 3200mAh 3S 30C Smart LiPo Battery: IC3
SPMX32004S30	14.8V 3200mAh 4S 30C Smart LiPo Battery: IC3
SPMX323S30	11.1V 3200mAh 3S 30C Smart G2 LiPo Battery: IC3
SPMX223S100	Smart S1200 DC Charger, 1x200W

Hardware

Location	Description	Quantity
Control Horns	2mm x 8mm Self-Tapping Screw	12
Main Retracts	2.6mm x 12 Self-Tapping Screw	4
Wing and Horizontal Stabilizer	M3 x 26 Countersunk Machine Screw	5
Motor Mount	2.6mm x 15mm Self-Tapping Screw	4
Motor	M3 x 6 Countersunk Machine Screw	4
Pilot Figure	2.6 mm x 25mm Self-Tapping Screw	2
Main Landing Gear Wheels	3mm E-Clip	2
Tail Wheel	1.5mm E-Clip	1

Important Federal Aviation Administration (FAA) Information

Use the QR code below to learn more about the **Recreational UAS Safety Test (TRUST)**, as was introduced by the 2018 FAA Reauthorization Bill. This free test is required by the FAA for all recreational flyers in the United States. The completed certificate must be presented upon request by any FAA or law enforcement official.



If your model aircraft weighs more than .55lbs or 250 grams, you are required by the FAA to register as a recreational flyer and apply your registration number to the outside of your aircraft. To learn more about registering with the FAA, use the QR code below.



AMA National Model Aircraft Safety Code

Effective January 1, 2018

A model aircraft is a non-human-carrying device capable of sustained flight within visual line of sight of the pilot or spotter(s). It may not exceed limitations of this code and is intended exclusively for sport, recreation, education and/or competition. All model flights must be conducted in accordance with this safety code and related AMA guidelines, any additional rules specific to the flying site, as well as all applicable laws and regulations.

As an AMA member I agree:

- I will not fly a model aircraft in a careless or reckless manner.
- I will not interfere with and will yield the right of way to all human-carrying aircraft using AMA's See and Avoid Guidance and a spotter when appropriate.
- I will not operate any model aircraft while I am under the influence of alcohol or any drug that could adversely affect my ability to safely control the model.
- I will avoid flying directly over unprotected people, moving vehicles, and occupied structures.
- I will fly Free Flight (FF) and Control Line (CL) models in compliance with AMA's safety programming.
- I will maintain visual contact of an RC model aircraft without enhancement other than corrective lenses prescribed to me. When using an advanced flight system, such as an autopilot, or flying First-Person View (FPV), I will comply with AMA's Advanced Flight System programming.
- I will only fly models weighing more than 55 pounds, including fuel, if certified through AMA's Large Model Airplane Program.
- I will only fly a turbine-powered model aircraft in compliance with AMA's Gas Turbine Program.
- I will not fly a powered model outdoors closer than 25 feet to any individual, except for myself or my helper(s) located at the flightline, unless I am taking off and landing, or as otherwise provided in AMA's Competition Regulation.
- I will use an established safety line to separate all model aircraft operations from spectators and bystanders.

Limited Warranty

What this Warranty Covers—Horizon Hobby, LLC, (Horizon) warrants to the original purchaser that the product purchased (the “Product”) will be free from defects in materials and workmanship at the date of purchase.

What is Not Covered—This warranty is not transferable and does not cover (i) cosmetic damage, (ii) damage due to acts of God, accident, misuse, abuse, negligence, commercial use, or due to improper use, installation, operation or maintenance, (iii) modification of or to any part of the Product, (iv) attempted service by anyone other than a Horizon Hobby authorized service center, (v) Product not purchased from an authorized Horizon dealer, (vi) Product not compliant with applicable technical regulations, or (vii) use that violates any applicable laws, rules, or regulations.

OTHER THAN THE EXPRESS WARRANTY ABOVE, HORIZON MAKES NO OTHER WARRANTY OR REPRESENTATION, AND HEREBY DISCLAIMS ANY AND ALL IMPLIED WARRANTIES, INCLUDING, WITHOUT LIMITATION, THE IMPLIED WARRANTIES OF NON-INFRINGEMENT, MERCHANTABILITY AND FITNESS FOR A PARTICULAR PURPOSE. THE PURCHASER ACKNOWLEDGES THAT THEY ALONE HAVE DETERMINED THAT THE PRODUCT WILL SUITABLY MEET THE REQUIREMENTS OF THE PURCHASER'S INTENDED USE.

Purchaser's Remedy—Horizon's sole obligation and purchaser's sole and exclusive remedy shall be that Horizon will, at its option, either (i) service, or (ii) replace, any Product determined by Horizon to be defective. Horizon reserves the right to inspect any and all Product(s) involved in a warranty claim. Service or replacement decisions are at the sole discretion of Horizon. Proof of purchase is required for all warranty claims. SERVICE OR REPLACEMENT AS PROVIDED UNDER THIS WARRANTY IS THE PURCHASER'S SOLE AND EXCLUSIVE REMEDY.

Limitation of Liability—HORIZON SHALL NOT BE LIABLE FOR SPECIAL, INDIRECT, INCIDENTAL OR CONSEQUENTIAL DAMAGES, LOSS OF PROFITS OR PRODUCTION OR COMMERCIAL LOSS IN ANY WAY, REGARDLESS OF WHETHER SUCH CLAIM IS BASED IN CONTRACT, WARRANTY, TORT, NEGLIGENCE, STRICT LIABILITY OR ANY OTHER THEORY OF LIABILITY, EVEN IF HORIZON HAS BEEN ADVISED OF THE POSSIBILITY OF SUCH DAMAGES. Further, in no event shall the liability of Horizon exceed the individual price of the Product on which liability is asserted. As Horizon has no control over use, setup, final assembly, modification or misuse, no liability shall be assumed nor accepted for any resulting damage or injury. By the act of use, setup or assembly, the user accepts all resulting liability. If you as the purchaser or user are not prepared to accept the liability associated with the use of the Product, purchaser is advised to return the Product immediately in new and unused condition to the place of purchase.

Law—These terms are governed by Illinois law (without regard to conflict of law principals). This warranty gives you specific legal rights, and you may also have other rights which vary from state to state. Horizon reserves the right to change or modify this warranty at any time without notice.

WARRANTY SERVICES

Questions, Assistance, and Services—Your local hobby store and/or place of purchase cannot provide warranty support or service. Once assembly, setup or use of the Product has been started, you must contact your local distributor or Horizon directly. This will enable Horizon to better answer your questions and service you in the event that you may need any assistance. For questions

or assistance, please visit our website at www.horizonhobby.com, submit a Product Support Inquiry, or call the toll free telephone number referenced in the Warranty and Service Contact Information section to speak with a Product Support representative.

Inspection or Services—If this Product needs to be inspected or serviced and is compliant in the country you live and use the Product in, please use the Horizon Online Service Request submission process found on our website or call Horizon to obtain a Return Merchandise Authorization (RMA) number. Pack the Product securely using a shipping carton. Please note that original boxes may be included, but are not designed to withstand the rigors of shipping without additional protection. Ship via a carrier that provides tracking and insurance for lost or damaged parcels, as Horizon is not responsible for merchandise until it arrives and is accepted at our facility. An Online Service Request is available at http://www.horizonhobby.com/content/service-center_render-service-center. If you do not have internet access, please contact Horizon Product Support to obtain a RMA number along with instructions for submitting your product for service. When calling Horizon, you will be asked to provide your complete name, street address, email address and phone number where you can be reached during business hours. When sending product into Horizon, please include your RMA number, a list of the included items, and a brief summary of the problem. A copy of your original sales receipt must be included for warranty consideration. Be sure your name, address, and RMA number are clearly written on the outside of the shipping carton.

NOTICE: Do not ship LiPo batteries to Horizon. If you have any issue with a LiPo battery, please contact the appropriate Horizon Product Support office.

Warranty Requirements—For Warranty consideration, you must include your original sales receipt verifying the proof-of-purchase date. Provided warranty conditions have been met, your Product will be serviced or replaced free of charge. Service or replacement decisions are at the sole discretion of Horizon.

Non-Warranty Service—Should your service not be covered by warranty, service will be completed and payment will be required without notification or estimate of the expense unless the expense exceeds 50% of the retail purchase cost. By submitting the item for service you are agreeing to payment of the service without notification. Service estimates are available upon request. You must include this request with your item submitted for service. Non-warranty service estimates will be billed a minimum of ½ hour of labor. In addition you will be billed for return freight. Horizon accepts money orders and cashier's checks, as well as Visa, MasterCard, American Express, and Discover cards. By submitting any item to Horizon for service, you are agreeing to Horizon's Terms and Conditions found on our website http://www.horizonhobby.com/content/service-center_render-service-center.

ATTENTION: Horizon service is limited to Product compliant in the country of use and ownership. If received, a non-compliant Product will not be serviced. Further, the sender will be responsible for arranging return shipment of the un-serviced Product, through a carrier of the sender's choice and at the sender's expense. Horizon will hold non-compliant Product for a period of 60 days from notification, after which it will be discarded.

10/15

Contact Information

Country of Purchase	Horizon Hobby	Contact Information	Address
United States of America	Horizon Service Center (Repairs and Repair Requests)	servicecenter.horizonhobby.com/RequestForm/	2904 Research Rd Champaign, Illinois, 61822 USA
	Horizon Product Support (Product Technical Assistance)	productsupport@horizonhobby.com 877-504-0233	
	Sales	websales@horizonhobby.com 800-338-4639	
European Union	Horizon Technischer Service Sales: Horizon Hobby GmbH	service@horizonhobby.eu +49 (0) 4121 2655 100	Hanskampring 9 D 22885 Barsbüttel, Germany

FCC Information

FCC ID: BRWSPMSR6200A

Supplier's Declaration of Conformity

FC **EFL F4U Corsair 1.2M BNF Basic (EFL18550)**: This device complies with part 15 of the FCC Rules. Operation is subject to the following two conditions: (1) This device may not cause harmful interference, and (2) this device must accept any interference received, including interference that may cause undesired operation.

CAUTION: Changes or modifications not expressly approved by the party responsible for compliance could void the user's authority to operate the equipment.

NOTE: This equipment has been tested and found to comply with the limits for a Class B digital device, pursuant to part 15 of the FCC Rules. These limits are designed to provide reasonable protection against harmful interference in a residential installation. This equipment generates, uses and can radiate radio frequency energy and, if not installed and used in accordance with the instructions, may cause harmful interference to radio communications.

However, there is no guarantee that interference will not occur in a particular installation. If this equipment does cause harmful interference to radio or television reception, which can be determined by turning the equipment off and on, the user is encouraged to try to correct the interference by one or more of the following measures:

- Reorient or relocate the receiving antenna.
- Increase the separation between the equipment and receiver.
- Connect the equipment into an outlet on a circuit different from that to which the receiver is connected.
- Consult the dealer or an experienced radio/TV technician for help.

Horizon Hobby, LLC
2904 Research Rd.,
Champaign, IL 61822
Email: compliance@horizonhobby.com
Web: HorizonHobby.com

IC Information

CAN ICES-3 (B)/NMB-3(B)

IC: 6157A-SPMSR6200A

This device contains license-exempt transmitter(s)/receivers(s) that comply with Innovation, Science, and Economic Development Canada's license-exempt RSS(s). Operation is subject to the following 2 conditions:

1. This device may not cause interference.
2. This device must accept any interference, including interference that may cause undesired operation of the device.

Compliance Information for the European Union

CE **EU Compliance Statement:**

EFL F4U Corsair 1.2M PNP (EFL18575): Hereby, Horizon Hobby, LLC declares that the device is in compliance with the following:

EU EMC Directive 2014/30/EU; RoHS 2 Directive 2011/65/EU;

RoHS 3 Directive - Amending 2011/65/EU Annex II 2015/863.

EFL F4U Corsair 1.2M BNF Basic (EFL18550): Hereby, Horizon Hobby, LLC declares that the device is in compliance with the following: EU Radio Equipment Directive 2014/53/EU, RoHS 2 Directive 2011/65/EU, RoHS 3 Directive - Amending 2011/65/EU Annex II 2015/863.

The full text of the EU declaration of conformity is available at the following internet address: <https://www.horizonhobby.com/content/support-render-compliance>.

Wireless frequency range and wireless output power:

Receiver:

2404–2476MHz

5.58dBm

EU Manufacturer of Record:

Horizon Hobby, LLC
2904 Research Road
Champaign, IL 61822 USA

EU Importer of Record:

Horizon Hobby, GmbH
Hanskampring 9
22885 Barsbüttel Germany

WEEE NOTICE:



This appliance is labeled in accordance with European Directive 2012/19/EU concerning waste of electrical and electronic equipment (WEEE). This label indicates that this product should not be disposed of with household waste. It should be deposited at an appropriate facility to enable recovery and recycling.



E328

HINWEIS

Alle Anweisungen, Garantien und andere Begleitdokumente können von Horizon Hobby, LLC nach eigenem Ermessen geändert werden. Um aktuelle Produktinformationen zu erhalten, besuchen Sie <http://www.horizonhobby.com> oder towerhobbies.com und klicken Sie auf die Registerkarte Support oder Ressourcen für dieses Produkt.

BEGRIFFSERKLÄRUNG

Die folgenden Begriffe werden in der gesamten Produktliteratur verwendet, um die Gefährdungsstufen im Umgang mit dem Produkt zu definieren:

WARNUNG: Verfahren, die bei nicht ordnungsgemäßer Durchführung womöglich Schäden an Eigentum, Kollateralschäden und schwere Verletzungen ODER höchstwahrscheinlich oberflächliche Verletzungen verursachen können.

ACHTUNG: Verfahren, die bei nicht ordnungsgemäßer Durchführung womöglich Schäden an physischem Eigentum UND schwere Verletzungen verursachen können.

HINWEIS: Verfahren, die bei nicht ordnungsgemäßer Durchführung womöglich Schäden an physischem Eigentum UND geringfügige oder keine Verletzungen verursachen können.



WARNUNG: Lesen Sie die GESAMTE Bedienungsanleitung, um sich vor Inbetriebnahme mit den Funktionen des Produkts vertraut zu machen. Eine nicht ordnungsgemäße Bedienung des Produkts kann das Produkt und persönliches Eigentum schädigen und schwere Verletzungen verursachen.

Dies ist ein hoch entwickeltes Produkt für den Hobbygebrauch. Es muss mit Vorsicht und Umsicht bedient werden und erfordert einige mechanische Grundfertigkeiten. Wird das Produkt nicht sicher und umsichtig verwendet, so könnten Verletzungen oder Schäden am Produkt oder anderem Eigentum entstehen. Dieses Produkt ist nicht für den Gebrauch durch Kinder ohne direkte Aufsicht eines Erwachsenen vorgesehen. Versuchen Sie nicht, das Produkt ohne Zustimmung von Horizon Hobby, LLC zu zerlegen, mit nicht kompatiblen Komponenten zu verwenden oder beliebig zu verbessern. Dieses Handbuch enthält Sicherheitshinweise sowie Anleitungen zu Betrieb und Wartung. Es ist unerlässlich, dass Sie alle Anleitungen und Warnungen in diesem Handbuch vor dem Zusammenbau, der Einrichtung oder der Inbetriebnahme lesen und diese befolgen, um eine korrekte Bedienung zu gewährleisten und Schäden bzw. schwere Verletzungen zu vermeiden.

14+ ALTERSEMPFEHLUNG: Nicht für Kinder unter 14 Jahren. Dies ist kein Spielzeug.

Sicherheitsmaßnahmen und Warnungen

Als Benutzer dieses Produkts sind ausschließlich Sie für einen Betrieb verantwortlich, der weder Sie selbst noch andere gefährdet, bzw. der weder das Produkt noch Eigentum anderer beschädigt.

- Halten Sie stets in alle Richtungen einen Sicherheitsabstand zu Ihrem Modell ein, um Kollisionen und Verletzungen zu vermeiden. Dieses Modell wird über ein Funksignal gesteuert. Funksignale können von außerhalb gestört werden, ohne dass Sie darauf Einfluss nehmen können. Störungen können zu einem vorübergehenden Verlust der Steuerungskontrolle führen.
- Betreiben Sie Ihr Modell stets auf offenen Geländen, weit ab von Autos, Verkehr und Menschen.
- Befolgen Sie die Anweisungen und Warnungen für dieses Produkt und jedwedes optionales Zubehörteil (Ladegeräte, wieder aufladbare Akkus etc.) stets sorgfältig.
- Halten Sie sämtliche Chemikalien, Kleinteile und elektrische Komponenten stets außer Reichweite von Kindern.
- Vermeiden Sie den Wasserkontakt aller Komponenten, die nicht speziell dafür ausgelegt und entsprechend geschützt sind. Feuchtigkeit beschädigt die Elektronik.
- Nehmen Sie niemals ein Element des Modells in Ihren Mund, da dies zu schweren Verletzungen oder sogar zum Tod führen könnte.
- Betreiben Sie Ihr Modell niemals mit schwachen Senderbatterien.
- Behalten Sie das Modell stets im Blick und unter Kontrolle.
- Verwenden Sie nur vollständig aufgeladene Akkus.
- Behalten Sie den Sender stets eingeschaltet, wenn das Modell eingeschaltet ist.
- Entfernen Sie stets den Akku, bevor Sie das Modell auseinandernehmen.
- Halten Sie bewegliche Teile stets sauber.
- Halten Sie die Teile stets trocken.
- Lassen Sie die Teile stets auskühlen, bevor Sie sie berühren.
- Entfernen Sie nach Gebrauch stets den Akku.
- Stellen Sie immer sicher, dass der Failsafe vor dem Flug ordnungsgemäß eingestellt ist.
- Betreiben Sie das Modell niemals bei beschädigter Verkabelung.
- Berühren Sie niemals sich bewegende Teile.



WARNUNG VOR GEFÄLSCHTEN PRODUKTEN: Sollten Sie jemals eine Spektrum Komponente ersetzen wollen, kaufen Sie die benötigten Ersatzteile immer bei Horizon Hobby oder einem von Horizon Hobby autorisierten Händler, um sicherzugehen, dass Sie beste Spektrum Qualität erhalten. Horizon Hobby, LLC lehnt jedwede Haftung, Garantie und Serviceleistung in Bezug auf, aber nicht ausschließlich für, Kompatibilitäts- und Leistungsansprüche von gefälschten Produkten oder Produkten, die angeben mit DSM oder Spektrum kompatibel zu sein, ab.

Enthaltene/Empfohlene Ausrüstung

	PNP PLUG-N-PLAY	BNF [®] BASIC
Motor: BL15 Bürstenloser Außenläufer, 850 Kv, 14-poliger Motor (EFLM4115)	Eingebaut	Eingebaut
Geschwindigkeitsregler: Avian 70A Smart Lite bürstenlos (SPMXAE70)	Eingebaut	Eingebaut
Servo: Querruder (2), Klappe (2), Höhenruder (1) und Seitenruder (1) 9 Gramm Servo (SPMSA330)	Eingebaut	Installed
Empfänger: Spektrum™ AR631 DSMX 6-Kanal AS3X und SAFE-Empfänger (SPMAR631)	Erforderliche	Installed
Empfohlener Akku: 14,8V 4S 2200mAh 30C LiPo (SP-MX22004S30)	Erforderliche	Erforderliche
Empfohlenes Ladegerät: 3S–4S LiPo Balance-Ladegerät	Erforderliche	Erforderliche
Empfohlener Sender: 2.4 Ghz Sender mit voller Reichweite und Spektrum DSM2/DSMX Technologie und einstellbaren Dual Rates (6 Kanal oder größer)	Erforderliche	Erforderliche

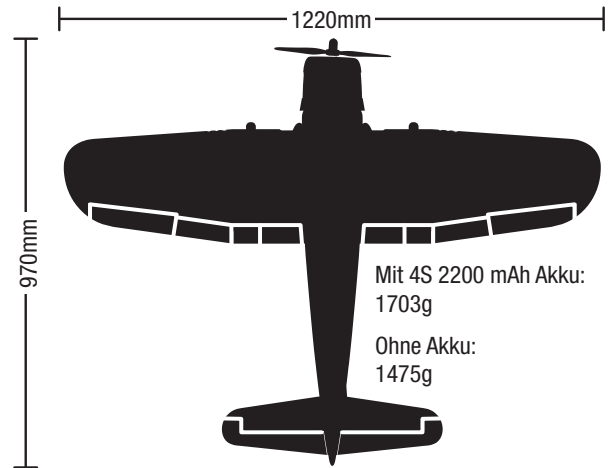

Inhaltsverzeichnis

Konfiguration des Senders BNF.....	22	Tipps zum Fliegen und Reparieren	31
Smart Technology und Flugzeiten.....	22	Wartung nach dem Flug.....	31
Auswahl und Montage des PNP-Empfängers.....	23	Werkseitige Einstellungen der Steuerhörner und Servo-Arme.....	32
Montage des Modells.....	24	Motorwartung	32
Montage des optionalen Abwurfanks	26	Fehlerbehebung AS3X®-System.....	32
Einstellen des Schwerpunktes	27	Fehlerbehebung.....	33
Steuerrichtungstests.....	27	Ersatzteile.....	34
Zentrieren der Kontrollen	27	Empfohlene Teile	34
Einsetzen der Flug-Akkus und Geschwindigkeitsregler.....	28	Optionale Teile	34
Failsafe und allgemeine Tipps für die Binding BNF	29	Hardware.....	34
Binden von Sender und Empfänger/SAFE Select ein- und ausschalten BNF..	29	Haftungsbeschränkung	35
Schalterbelegung von SAFE Select BNF	30	Garantie und Service Kontaktinformationen.....	36
Integrierte Geschwindigkeitsregler-Telemetrie.....	30	Konformitätshinweise für die Europäische Union	36
Trimmung während des Fluges BNF.....	31		



©2022 Horizon Hobby, LLC.

E-flite, Plug-N-Play, Bind-N-Fly, BNF, the BNF logo, DSM, DSM2, DSMX, Spektrum AirWare, EC3, IC3, AS3X, SAFE, the SAFE logo, ModelMatch, and the Horizon Hobby logo are trademarks or registered trademarks of Horizon Hobby, LLC.

The Spektrum trademark is used with permission of Bachmann Industries, Inc.

All other trademarks, service marks and logos are property of their respective owners.

US 8,672,726 US 9,056,667 US 9,753,457. US 10,078,329. US 9,930,567. US 10,419,970. Other patents pending.

<http://www.horizonhobby.com/>