



EDGE 540 V3

77.5" wingspan 35-40cc

Code : SEA 383

ASSEMBLY MANUAL



Specifications:

Wingspan	----- 75.5 in-----	197 cm.
Wing Area	----- 1023 sp.in-----	66 sq.dm.
Weight	----- 13 lbs-----	5.9 kg.
Length	----- 71 in-----	179 cm.
Engine	----- 35-40cc.	
Radio	----- 6 channels with 6 servos.	



INTRODUCTION

Thank you for choosing the **Edge 540 V3, 77.5" wingspan 35-40cc** ARTF by **SG MODELS**. The **Edge 540 V3, 77.5" wingspan 35-40cc** was designed with the intermediate/advanced sport flyer in mind. It is a semi scale airplane which is easy to fly and quick to assemble. The airframe is conventionally built using balsa, plywood to make it stronger than the average ARTF, yet the design allows the aeroplane to be kept light. You will find that most of the work has been done for you already. The motor mount has been fitted and the hinges are pre-installed. Flying the **Edge 540 V3, 77.5" wingspan 35-40cc** is simply a joy.

This instruction manual is designed to help you build a great flying aeroplane. Please read this manual thoroughly before starting assembly of your **Edge 540 V3, 77.5" wingspan 35-40cc** Use the parts listing below to indentify all parts.

WARNING

Please be aware that this aeroplane is not a toy and if assembled or used incorrectly it is capable of causing injury to people or property. WHEN YOU FLY THIS AEROPLANE YOU ASSUME ALL RISK & REPONSIBILITY.

If you are inexperienced with basic R/C flight we strongly recommend you contact your R/C supplier and join your local R/C model Flying Club. R/C Model Flying Clubs offer a variety of training procedures designed to help the new pilot on his way to successful R/C flight. They will also be able to advise on any insurance and safety regulations that may apply.

KIT CONTENTS

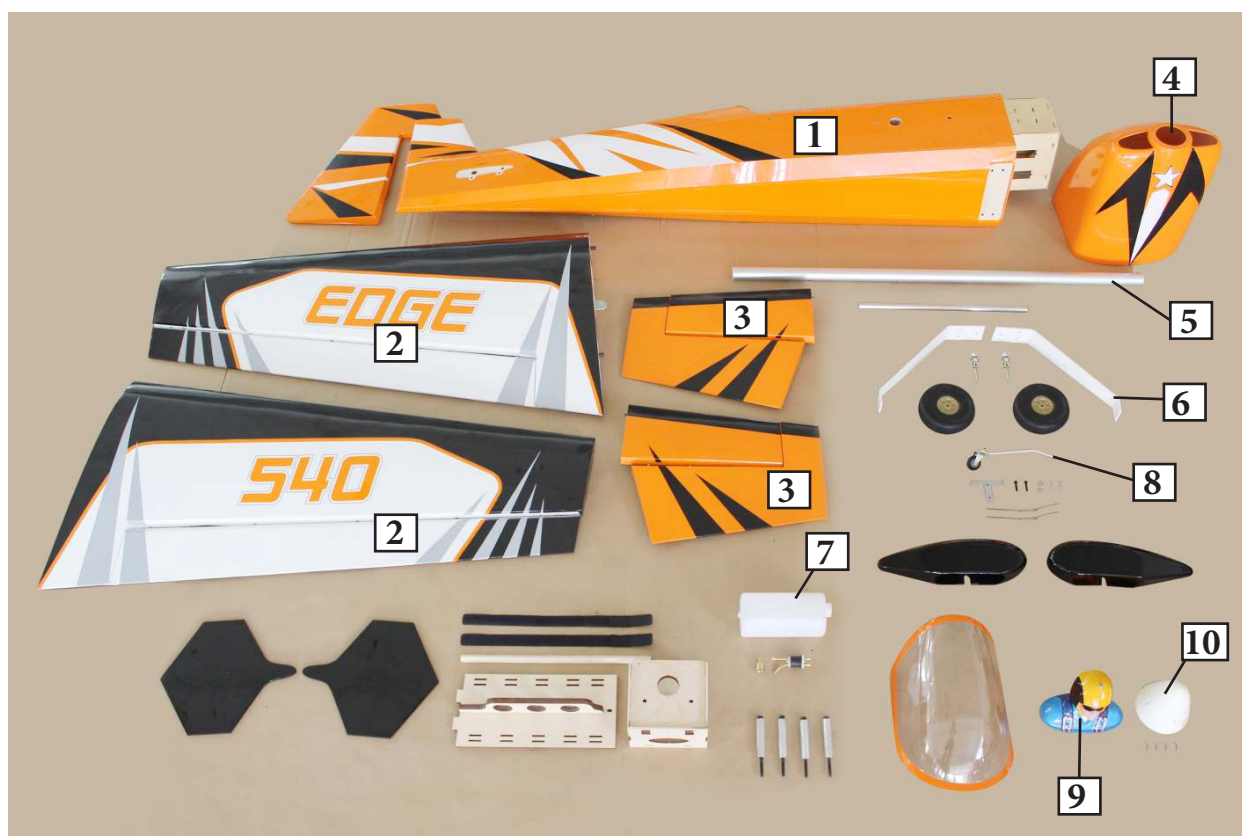

KIT CONTENTS

**SEA383 Edge 540 V3, 77.5" wingspan
35-40cc**

1. Fuselage
2. Wing set (2)
3. Tail set (2)
4. Cowling
5. Wing tube
6. Landing gear
7. Fuel tank
8. Tail wheel
9. Pilot
10. Spinner

ADDITIONAL ITEMS REQUIRED

- 35-40cc gasoline engine.
- Computer radio 6 channel with 6 servos.
- Glow plug to suit engine.
- Propeller to suit engine 20x8-21x10.
- Protective foam rubber for radio system.

TOOLS & SUPPLIES NEEDED

- Thin cyanoacrylate glue.
- Medium cyanoacrylate glue.
- 30 minute epoxy.
- 5 minute epoxy.
- Hand or electric drill.
- Assorted drill bits.
- Modelling knife.
- Straight edge ruler.
- 2mm ball driver.
- Phillips head screwdriver.
- 220 grit sandpaper.
- 90° square or builder's triangle.
- Wire cutters.
- Masking tape & T-pins.
- Thread-lock.
- Paper towels.

INSTALL THE AILERONS

Please see pictures below.

1.

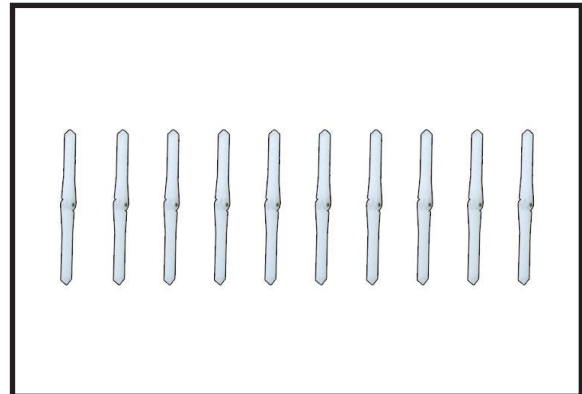

2.

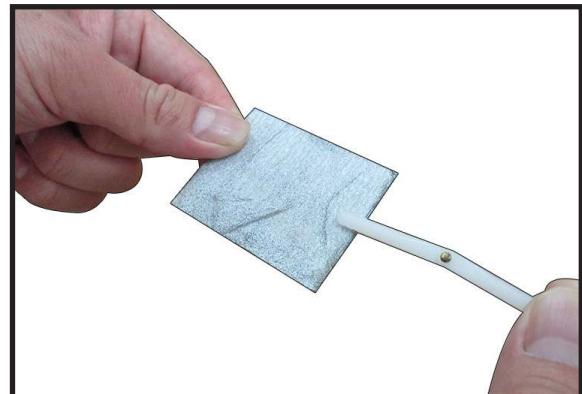

Remove the ailerons from the wing and remove the hinges.

Use a small piece of rough sandpaper to scuff the hinges for better epoxy adhesion. Do this to all aileron hinges.

3.

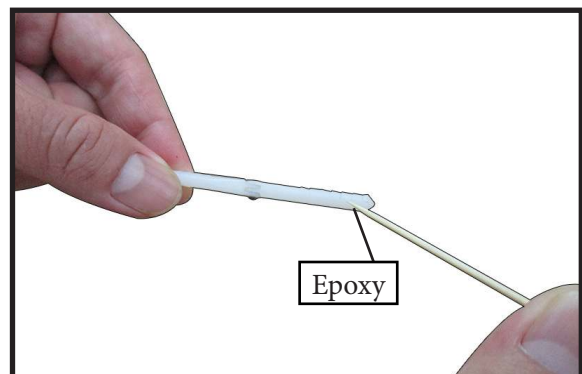

Apply epoxy to each hinge where it will be inserted into the ailerons. Tip: Apply some petroleum jelly to the metal pin hinge area to keep epoxy from interfering with smooth operation of hinge.

4.

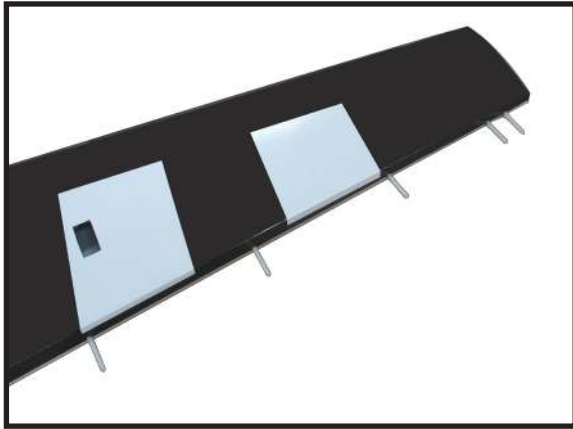

Insert all four hinges in the ailerons at this time. Make sure hinges move up and down in right direction and not side to side!

5.

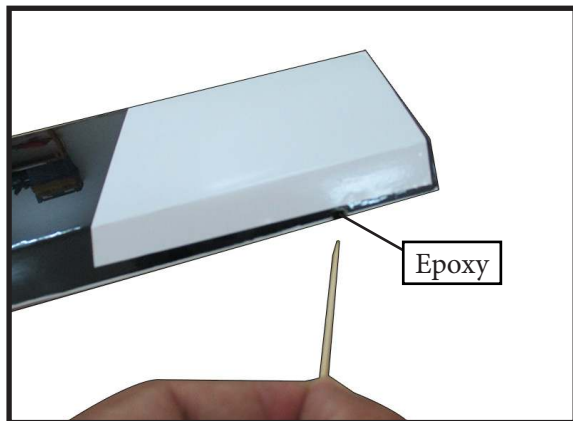

Apply epoxy into each of the holes in the ailerons using a spare piece of pushrod wire or toothpick.

Make sure to use enough epoxy so it securely adheres the hinge to the surfaces.

Do not use an excessive amount of epoxy when gluing the hinges so that it expels from the hinge area.

6.

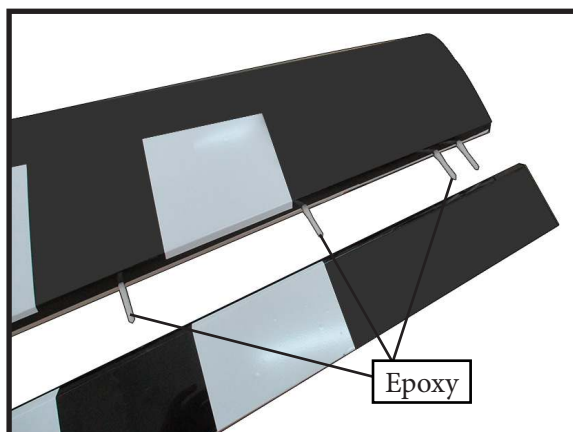

7.



8.



Check the fit of the aileron to the wing. The top of the ailerons will align to the top of the wing. Make sure movement is smooth and bind free.

We prefer 30-minute epoxy to allow enough working time during the hinge installation.

INSTALL THE AILERONS CONTROL HORN

1.



Prepare the aileron control horns by sanding the section that extends into the control surface with medium grit sand paper. Use isopropyl alcohol and a paper towel to remove any excess debris from the control horn.

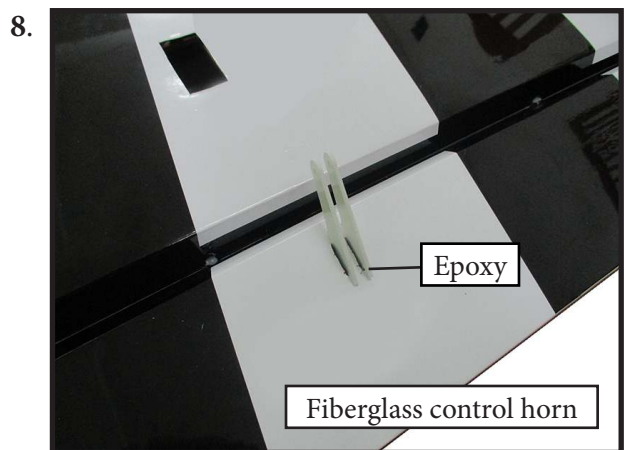
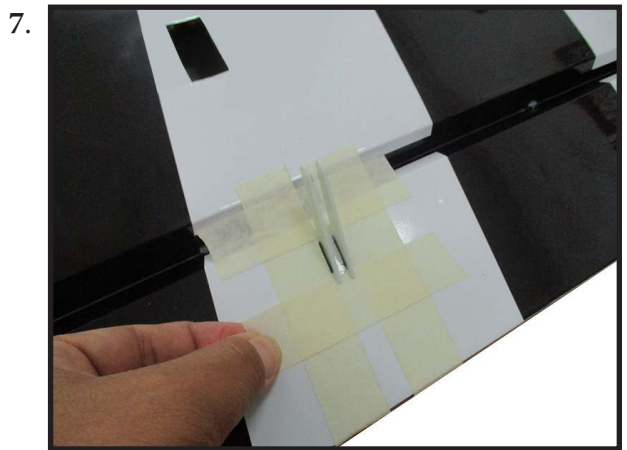
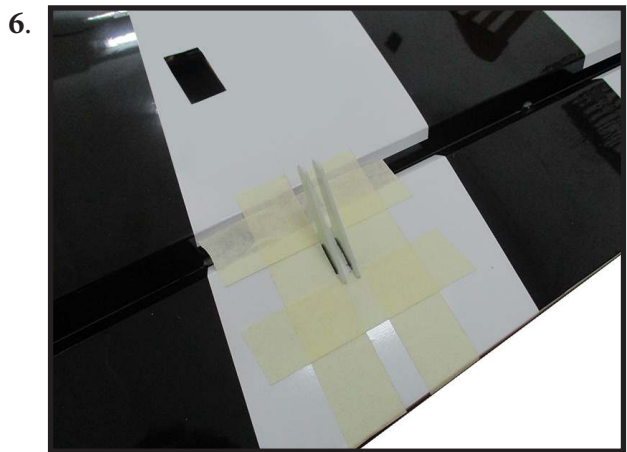
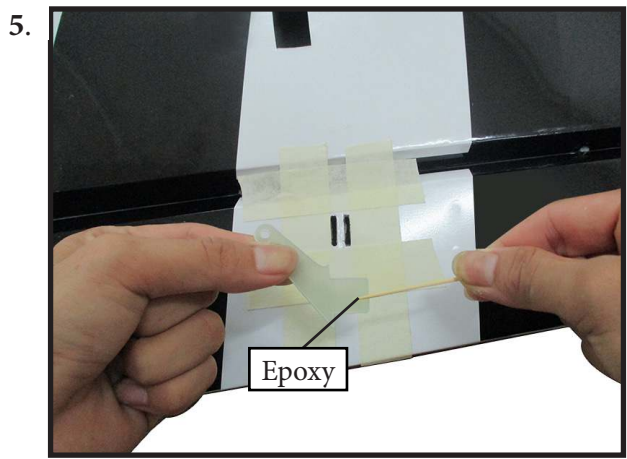
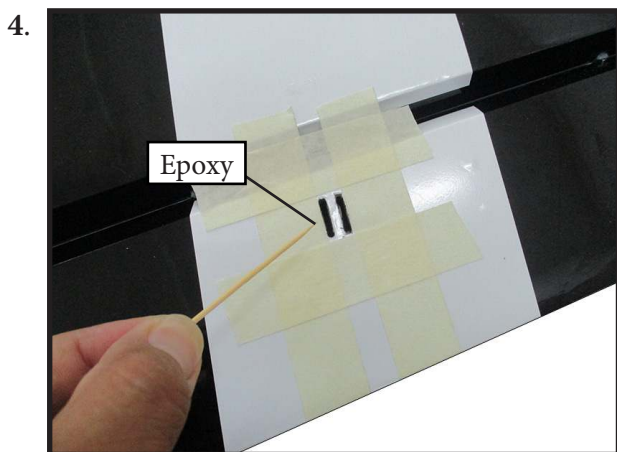
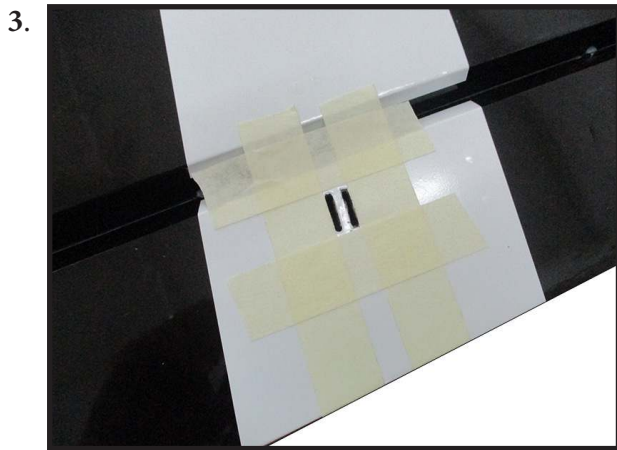
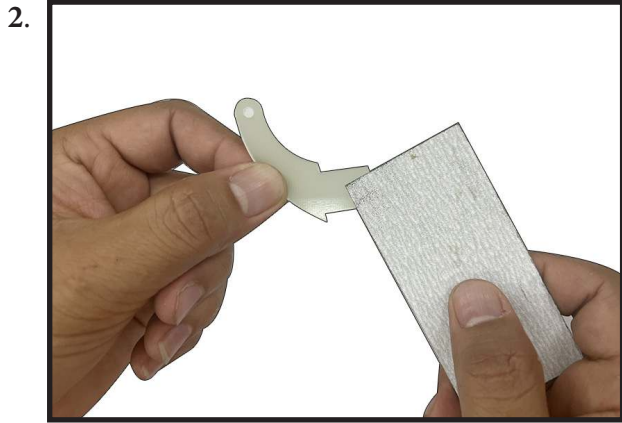

INSTALLING THE AILERON SERVOS

Please study images below.

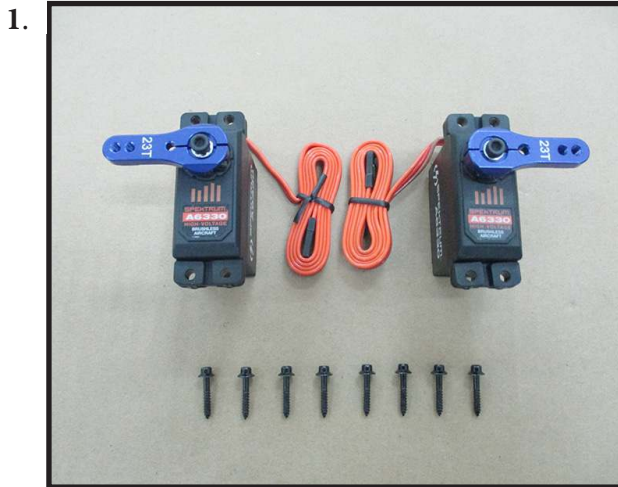

Maximum Servo spec.

Torque : 126.6 oz-in (9.11 kg-cm) @ 6.0V;
178 oz-in (12.82 kg-cm) @ 7.4V;
248 oz-in (17.86 kg-cm) @ 8.4V

NOTE : servos arm for aileron is not provided from manufacturer.

Layout the servo on the wing to test fit the installation and ensure servo lead is the correct length.

Attach the extension to the servo lead and secure with Safety Clip, safety wire, tape or other method. Ensure the plugs will not come apart from vibration or light tension.



Fasten the pull string from the servo hole to the male plug of the servo extension.

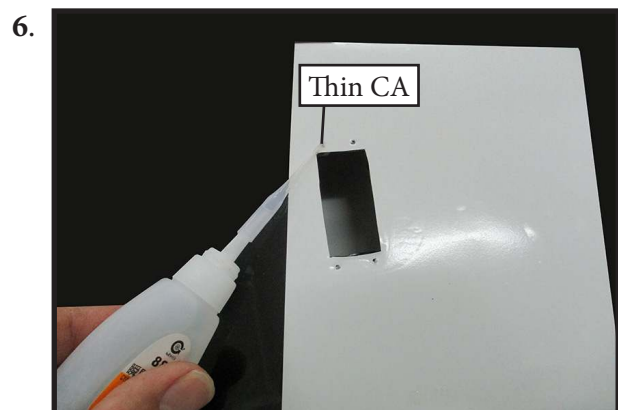
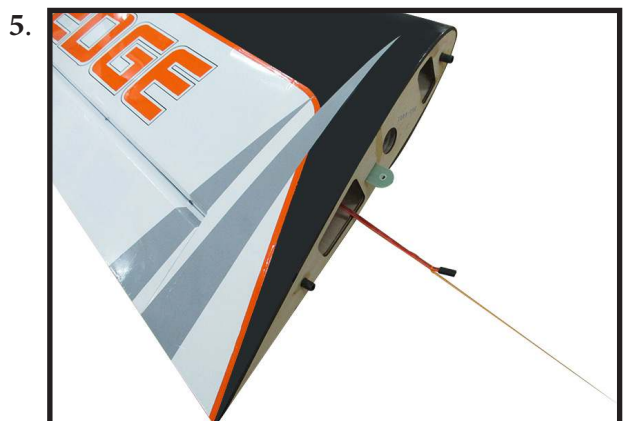
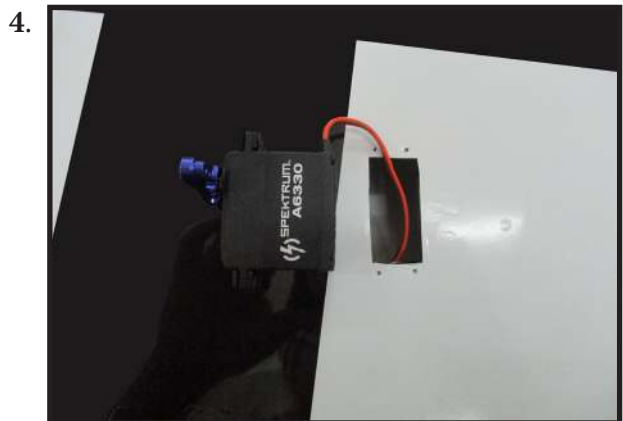
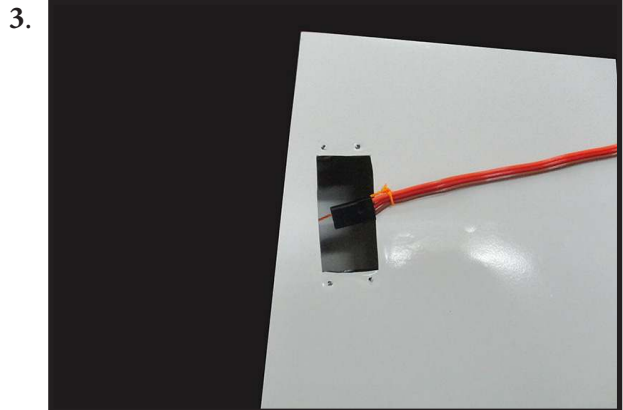

Install servo with servo mounting screws.

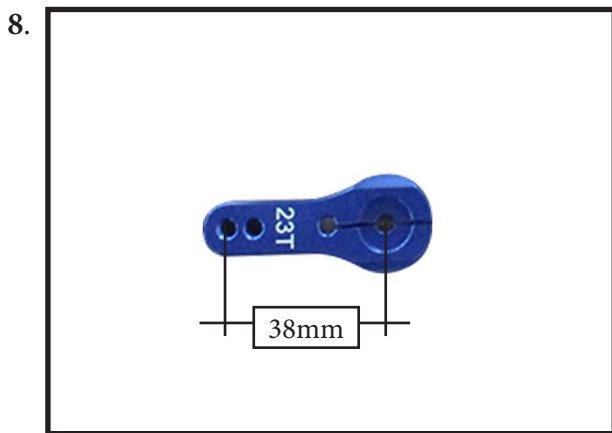
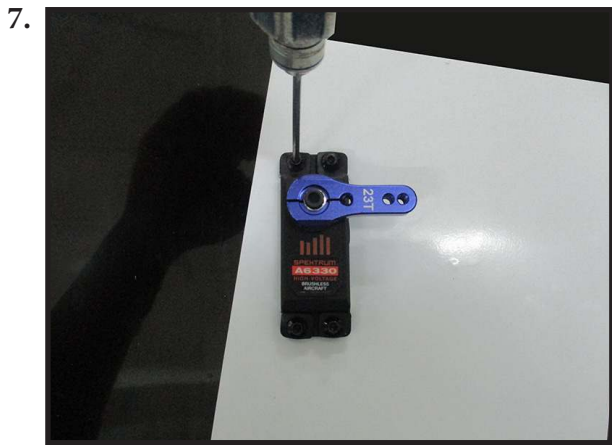

INSTALLING THE AILERON PUSHROD

Please study images below.

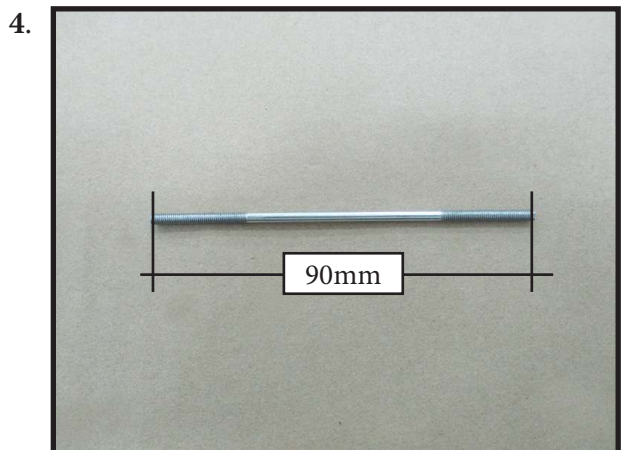
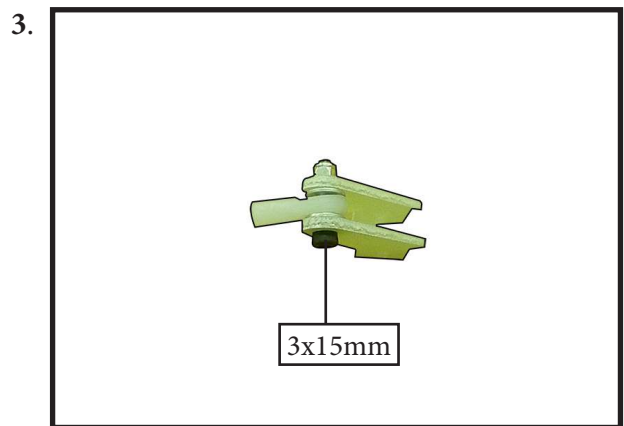
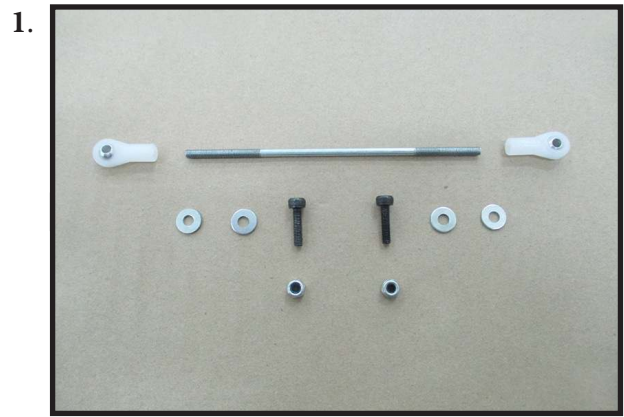

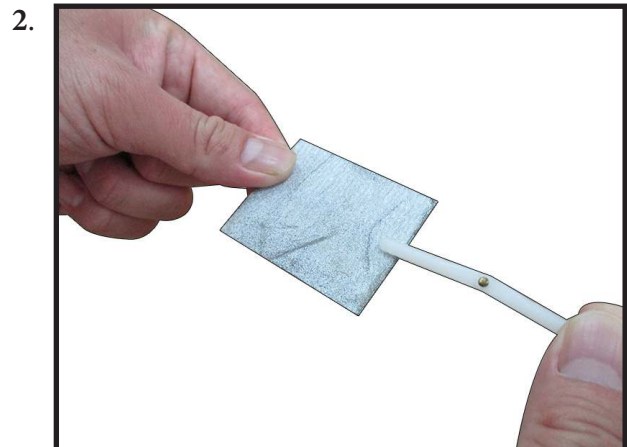
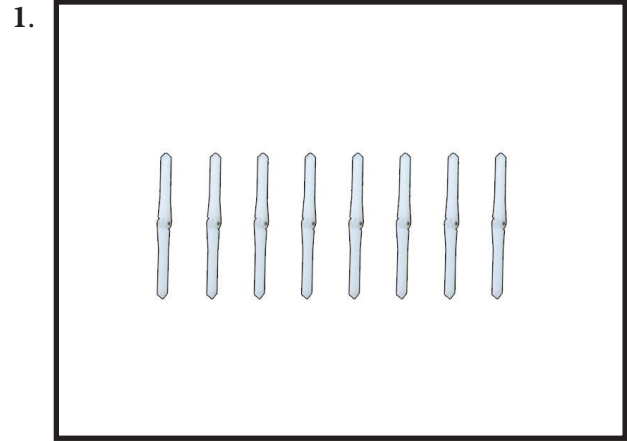
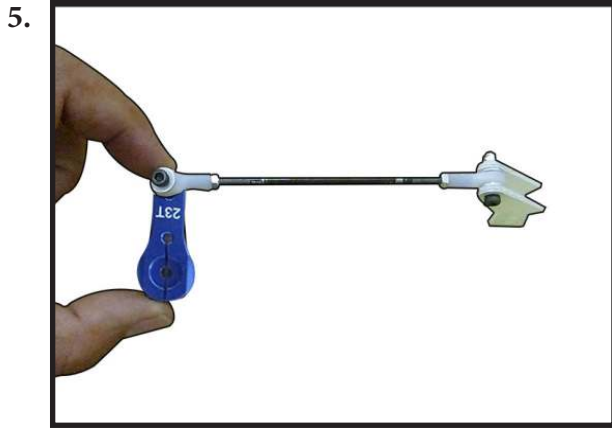

Repeat all the above steps for the other wing.

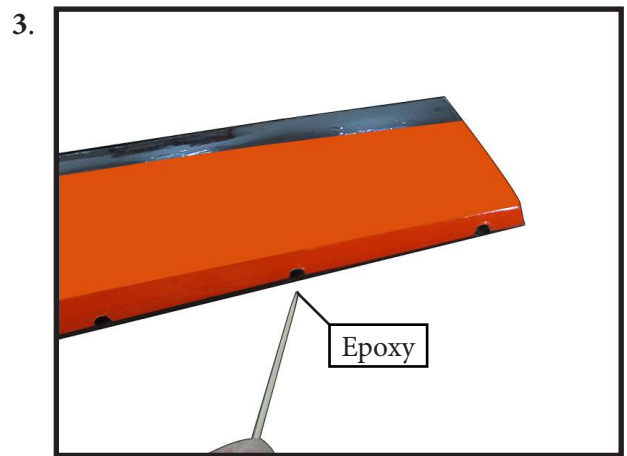

INSTALL HINGE FOR STABILIZER AND ELEVATOR

Please study images below.

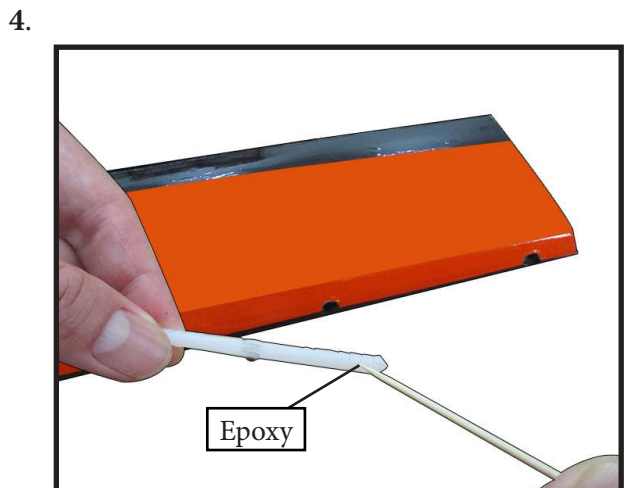

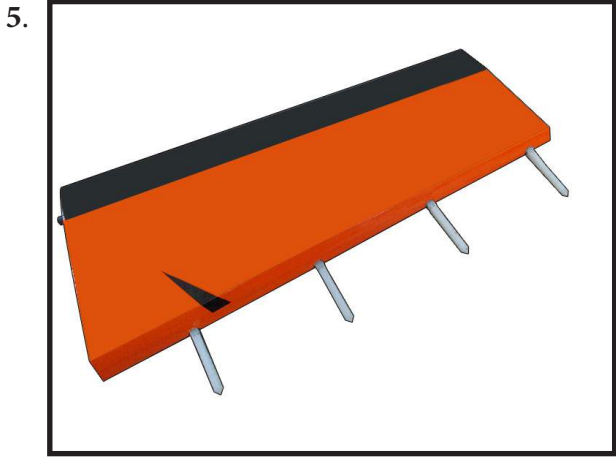

INSTALL ELEVATOR CONTROL HORN

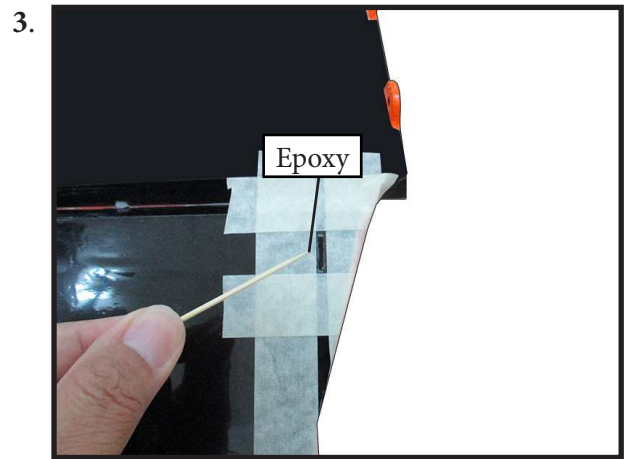
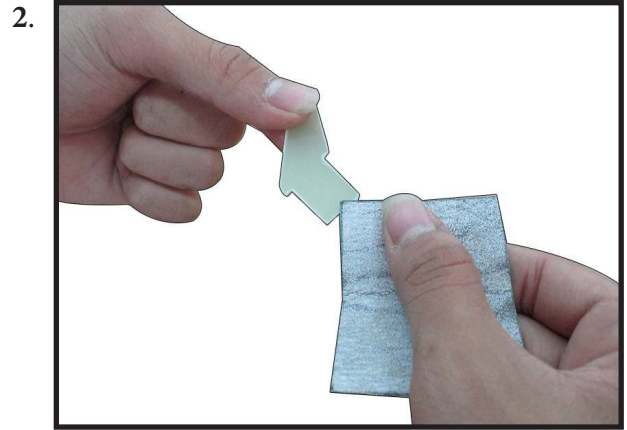
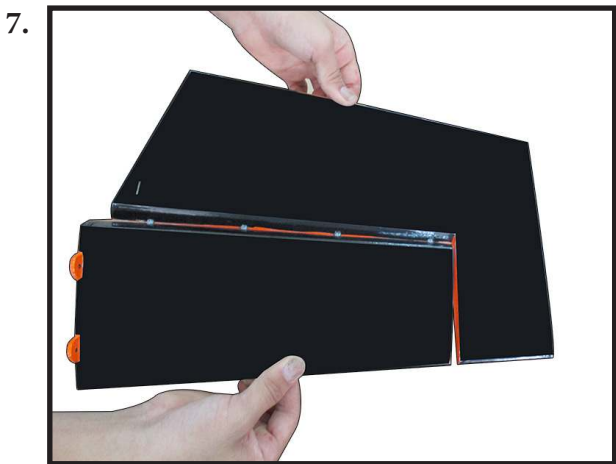
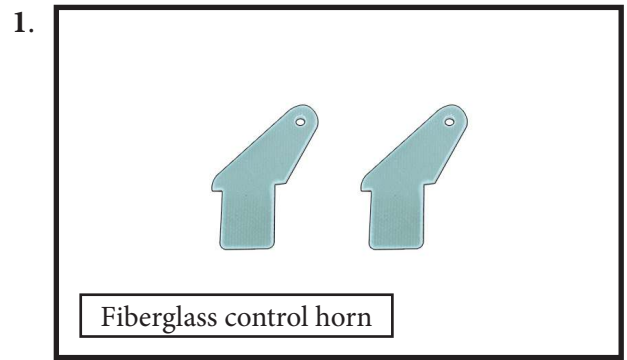

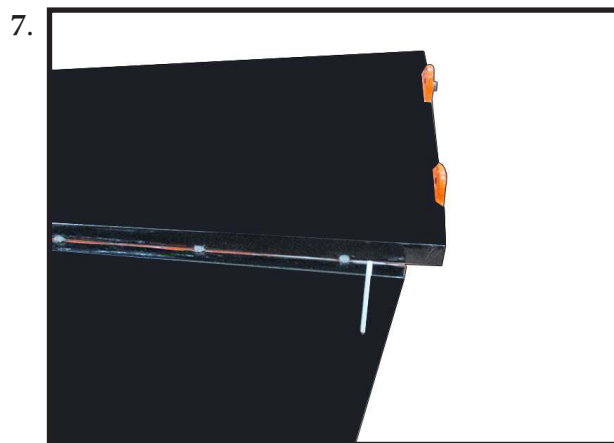
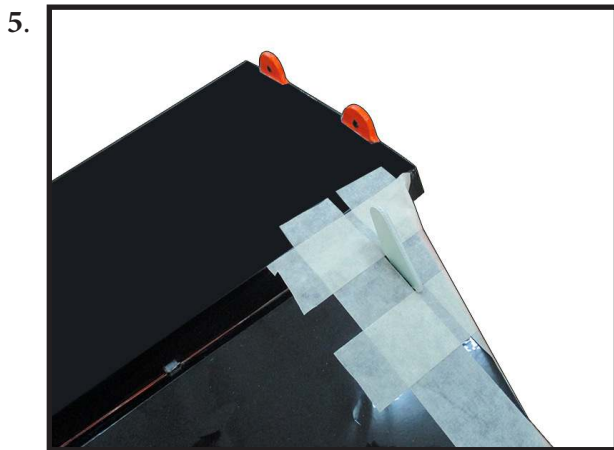
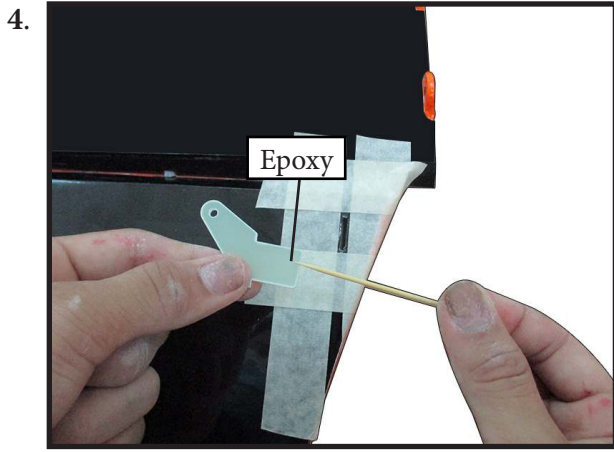

You cut horizontal tail sever hole.



Maximum Servo spec.
Torque : 126.6 oz-in (9.11 kg-cm) @ 6.0V;
178 oz-in (12.82 kg-cm) @ 7.4V; 248 oz-in (17.86 kg-cm) @ 8.4V



INSTALL HINGE FOR RUDDER AND FIN

Please study images below.

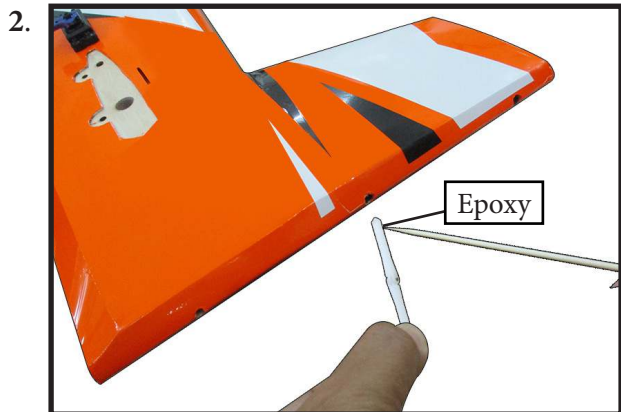
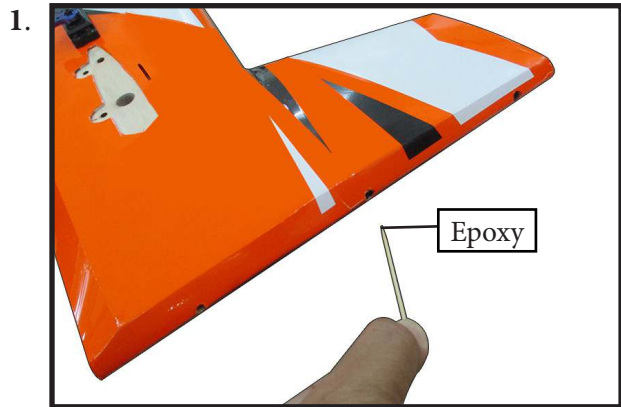

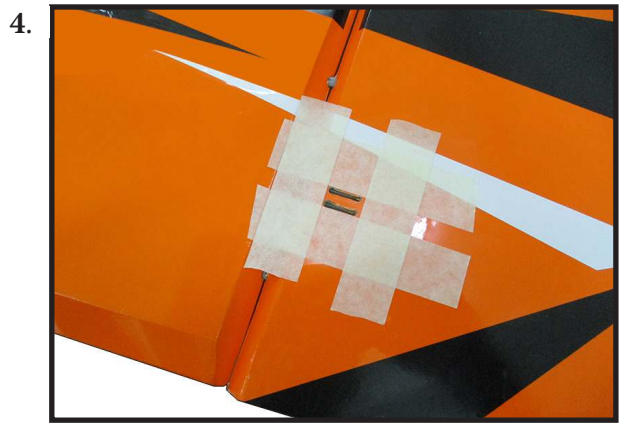

INSTALL RUDDER CONTROL HORN

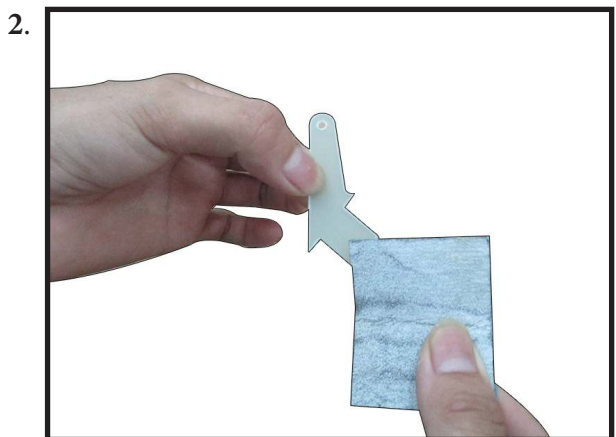
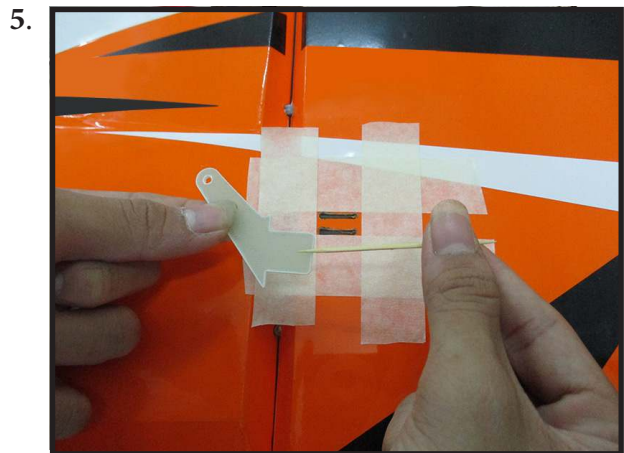
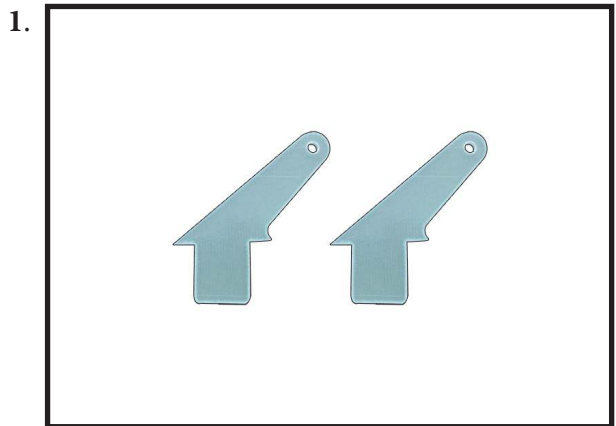



HORIZONTAL TAIL INSTALLATION

Please study images below.

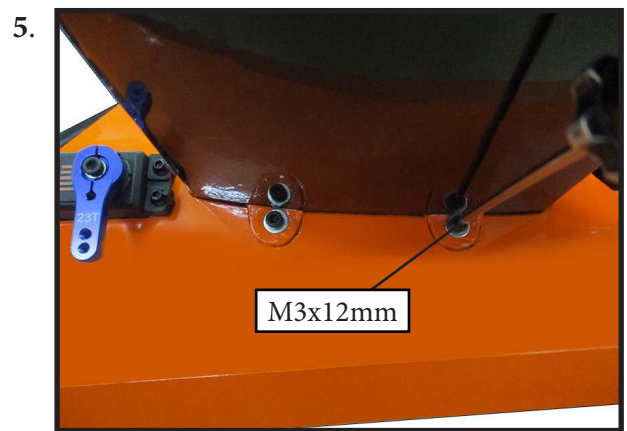

ELEVATOR PUSHROD INSTALLATION

Please study images below.

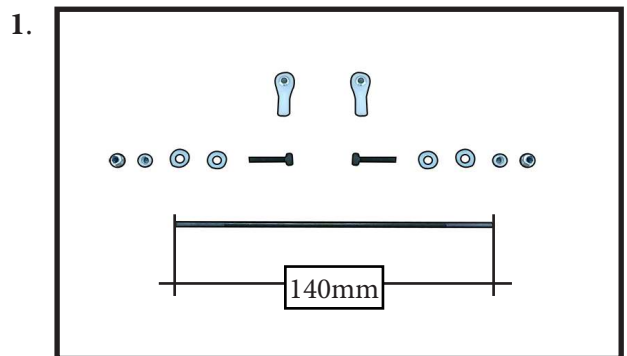

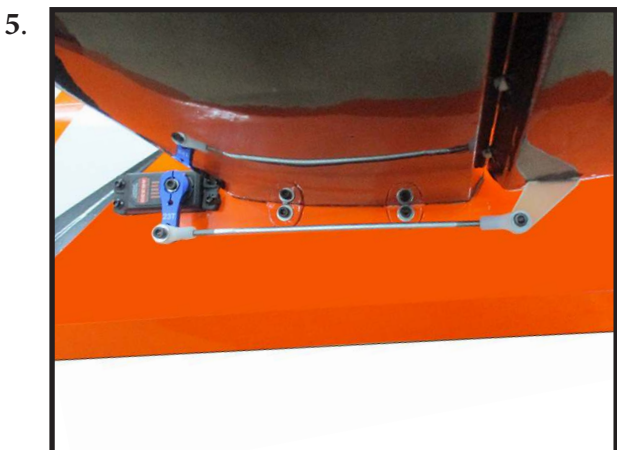
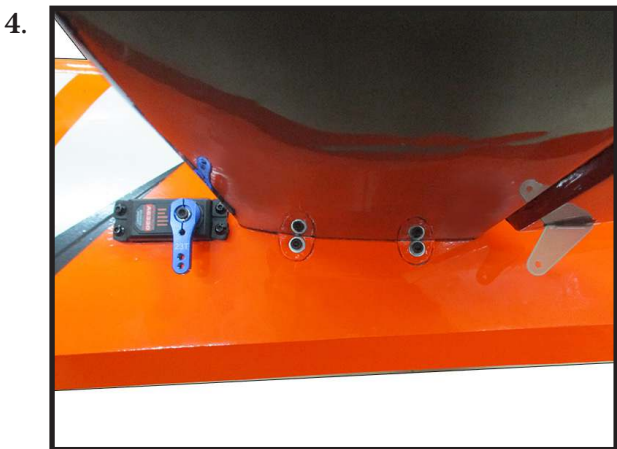
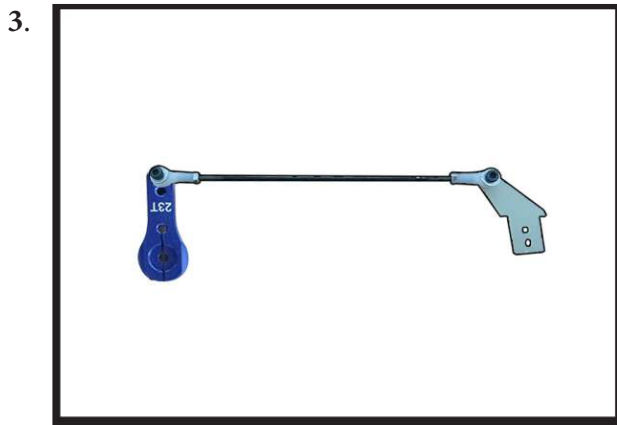
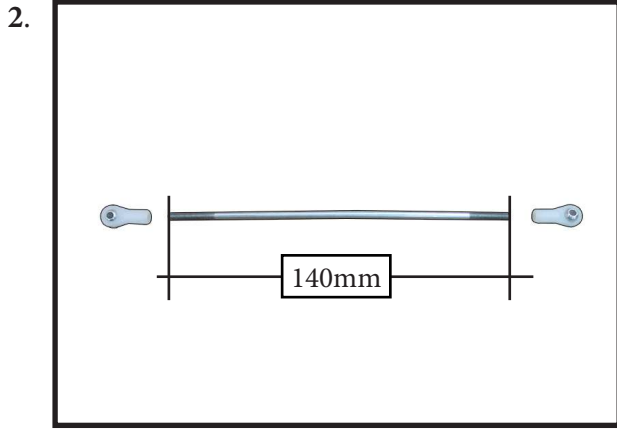

INSTALL RUDDER CABLE AND SERVO

NOTE : servos arm is not provided from manufacturer.

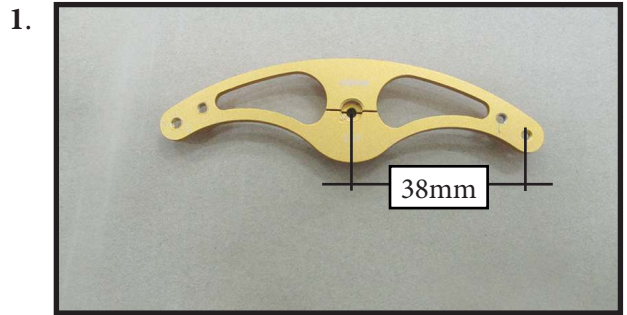

Tape the rudder balance tab to the top leading edge of the vertical fin in the neutral position as shown. This ensures the rudder is straight when the cables are attached.



Thread the rudder cable through a brass swage tube, then the threaded coupler, and back through the brass swage tube on both sides. Pull light tension on the cable through the coupler on both sides as shown.

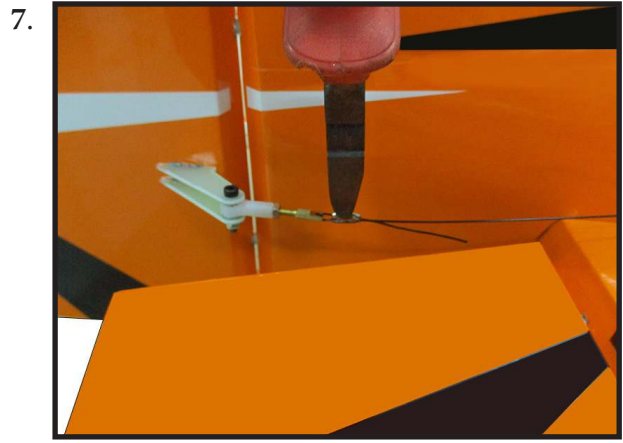
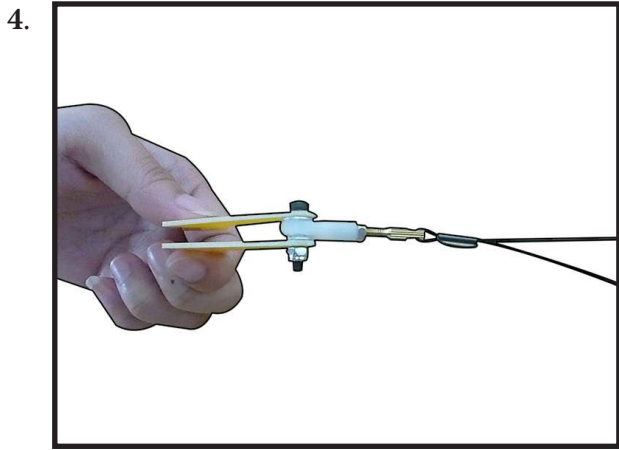

Cut off excess cable as shown.



Loop the cable back through the brass swage tube and tighten the second loop through the brass swage tube as shown.

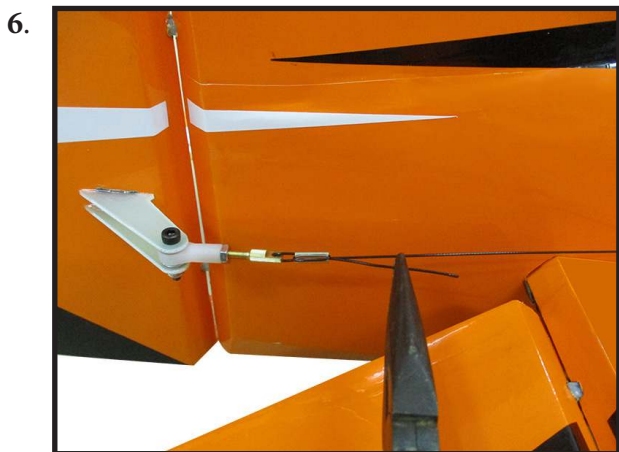

Crimp the brass tube with a crimping tool or pliers.



11.



Feed one rudder cable through the pre installed cable exit tube in the rear of the fuse toward the front of the fuse. Repeat for other side.

12.



Thread cable through brass swage tube.

13.



Thread cable through the threaded coupler hole, and back through the brass swage tube as shown.

Loop the cable back through the brass swage tube and pull tight.

14.

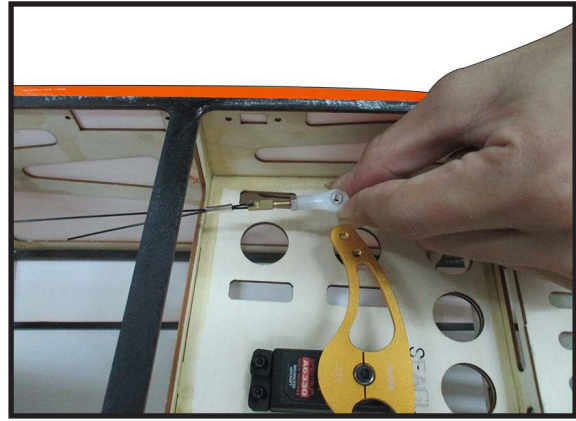

15.

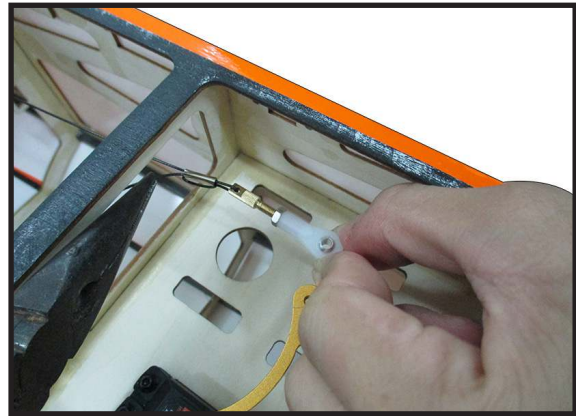

Crimp the brass swage tube with a crimping tool or pliers.

16.

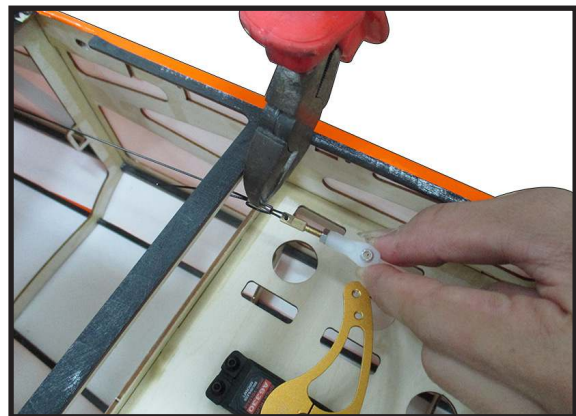

Cut off excess cable as shown.

17.

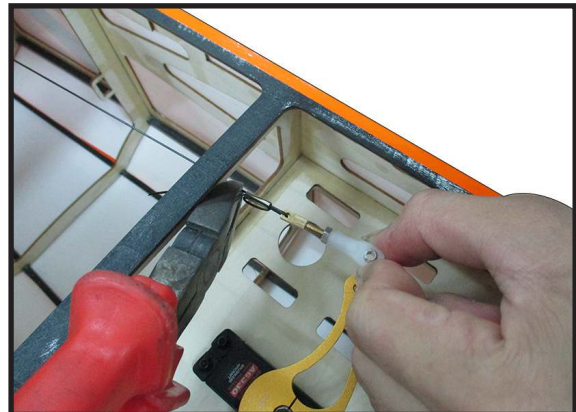

18.

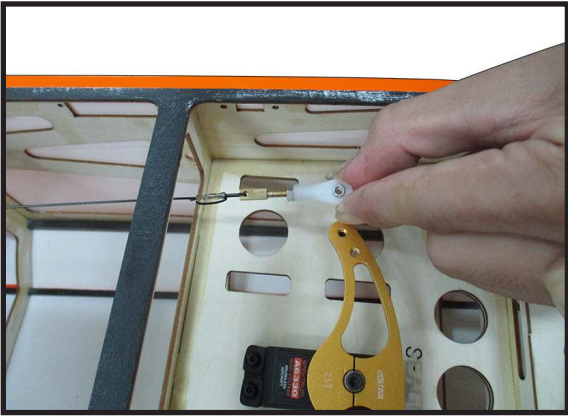

19.



TAILWHEEL INSTALLATION

Locate items necessary to install tailwheel.

1.

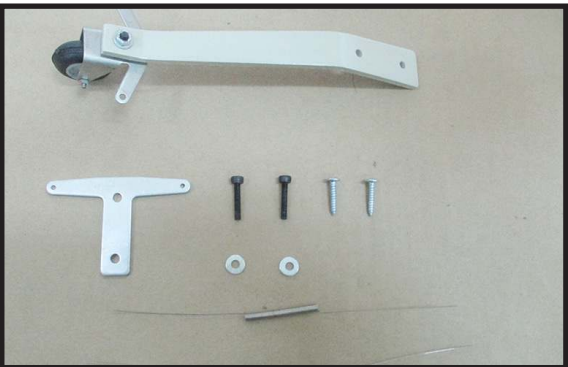

2.

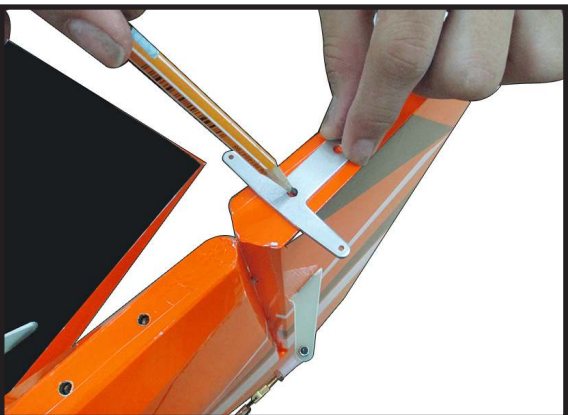

3.

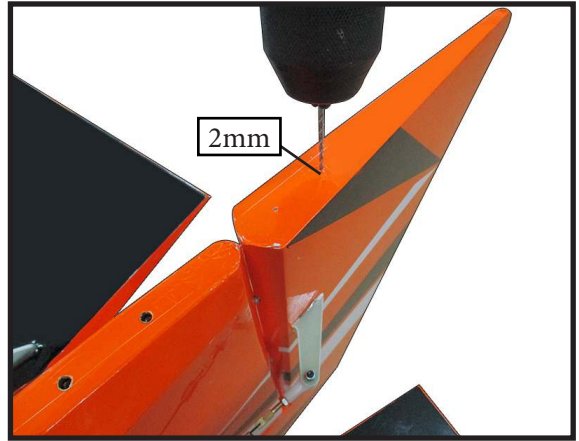

4.

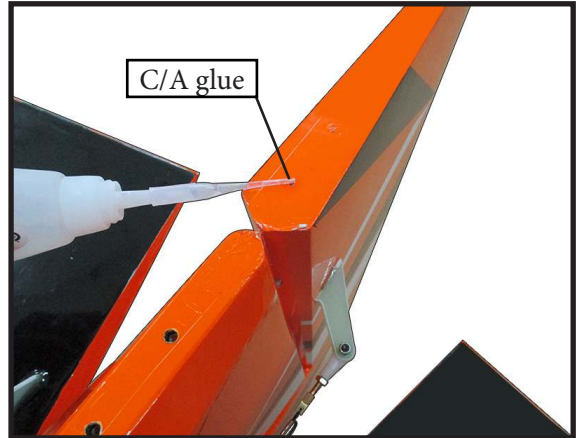

5.

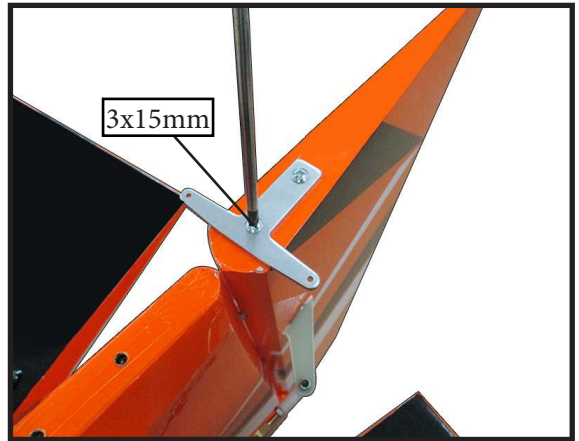

6.

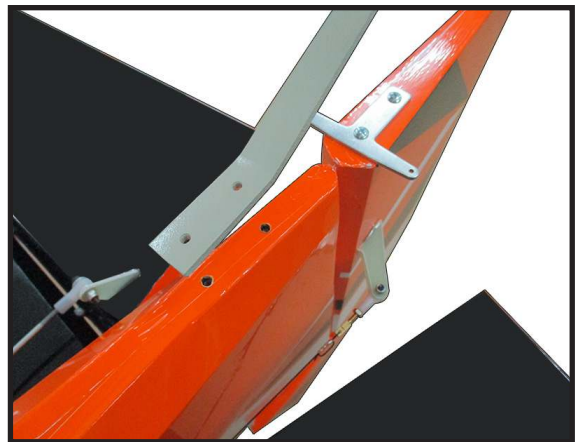

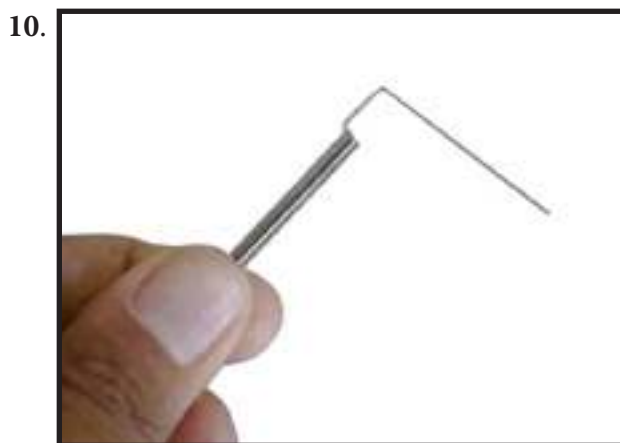
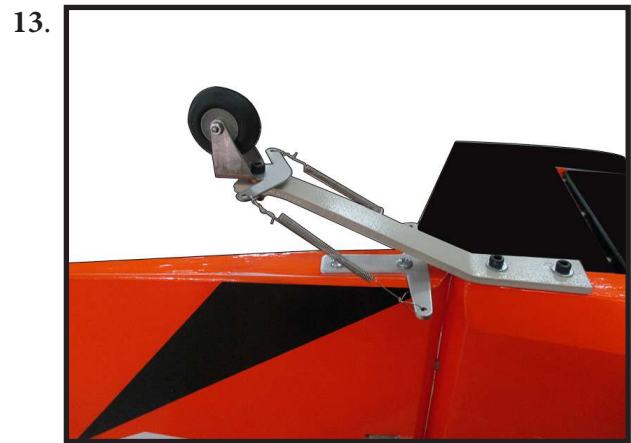
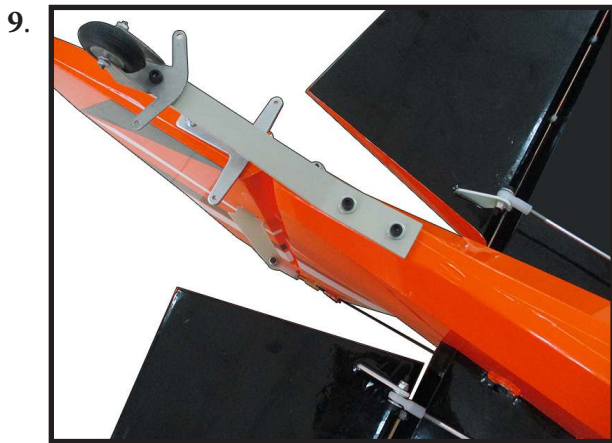
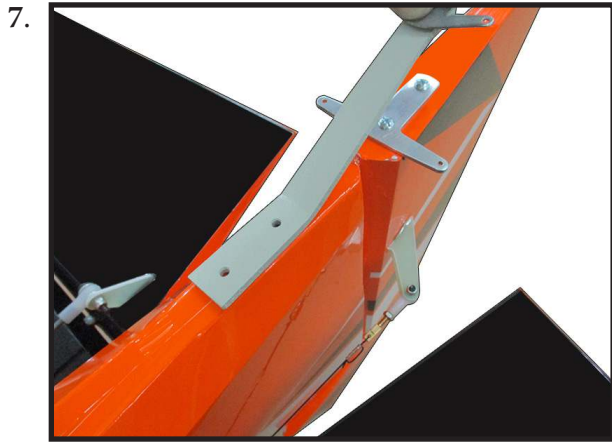

INSTALLING THE MAIN LANDING GEAR TO FUSELAGE

Please study images below.

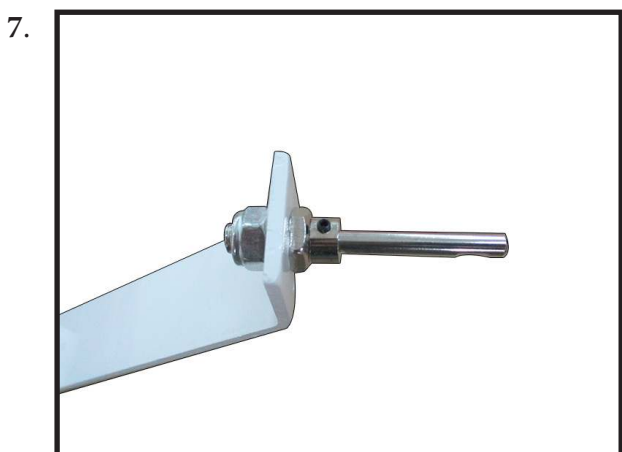
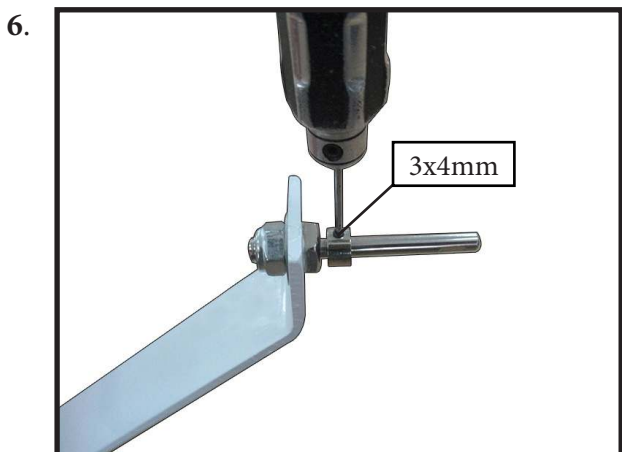
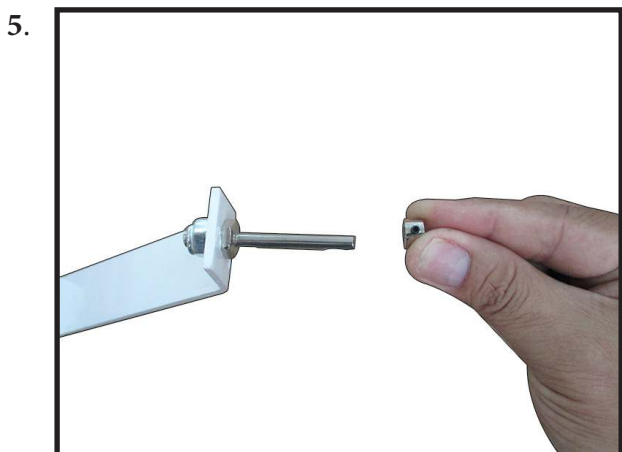
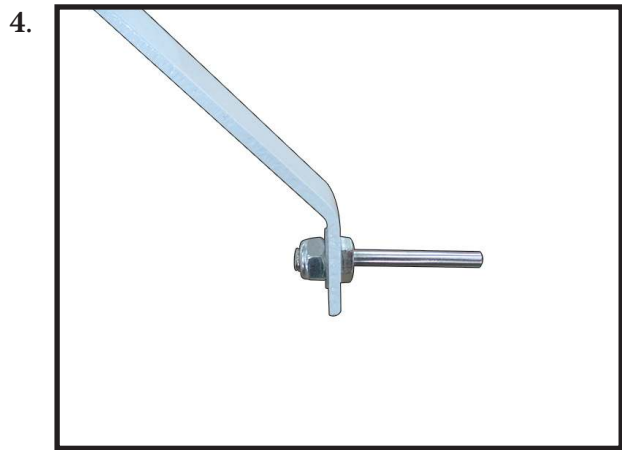
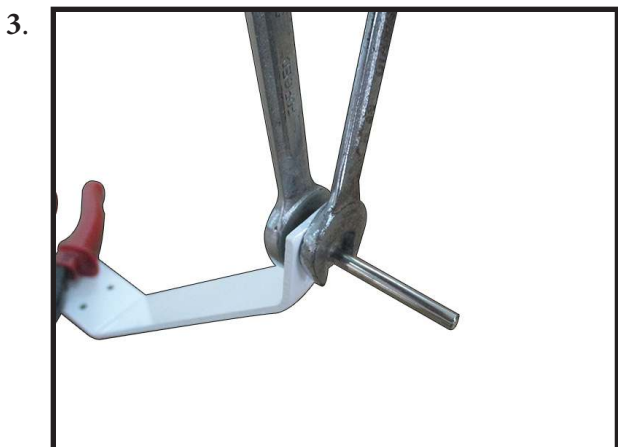
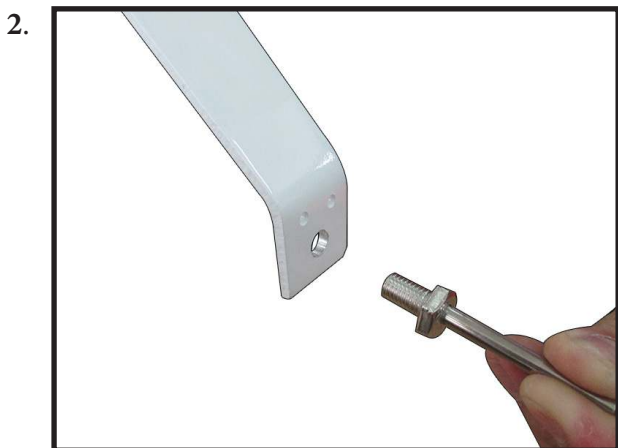
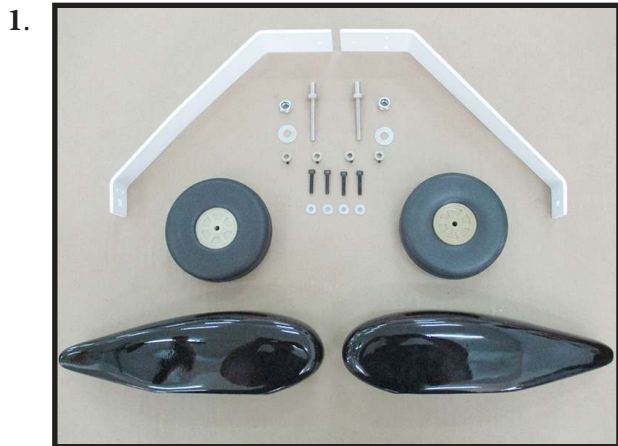

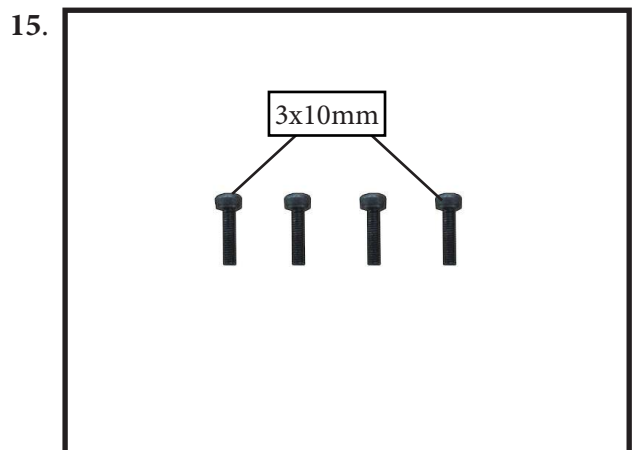
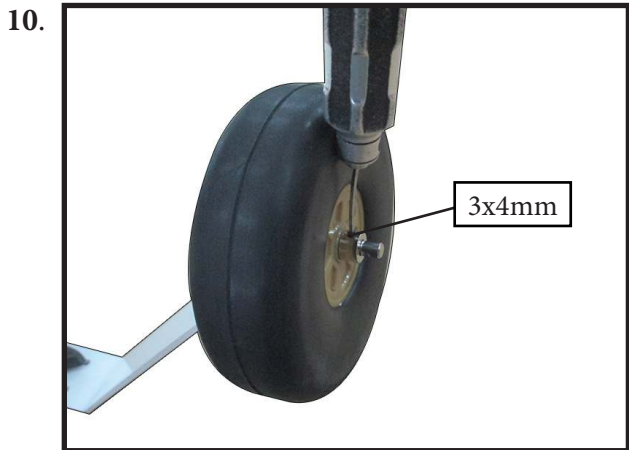
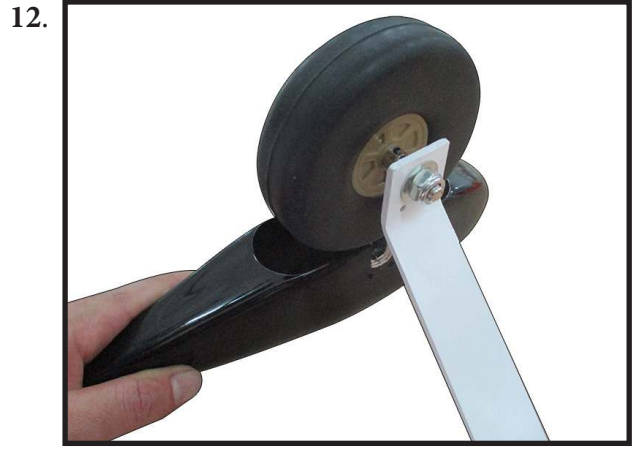
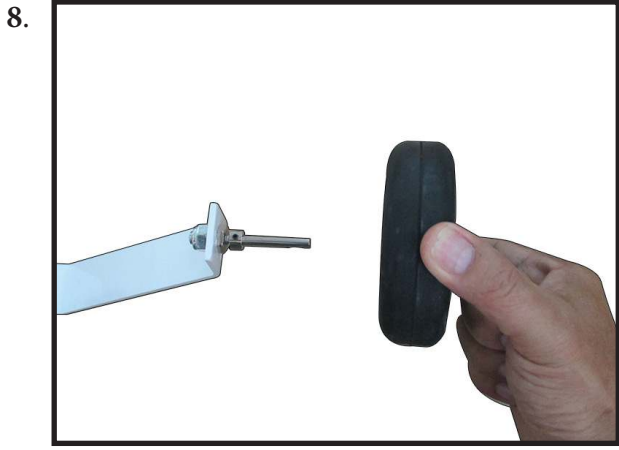

16.

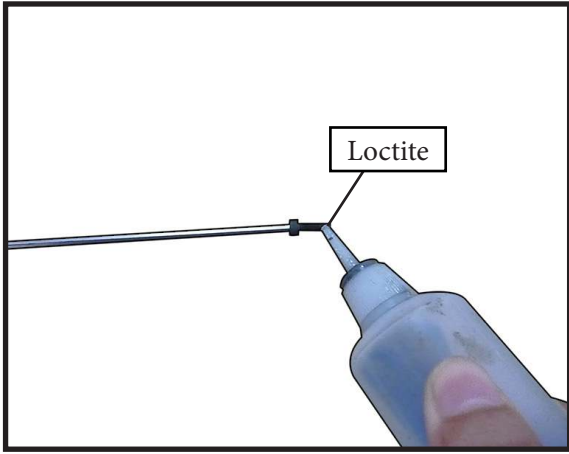

20.



17.

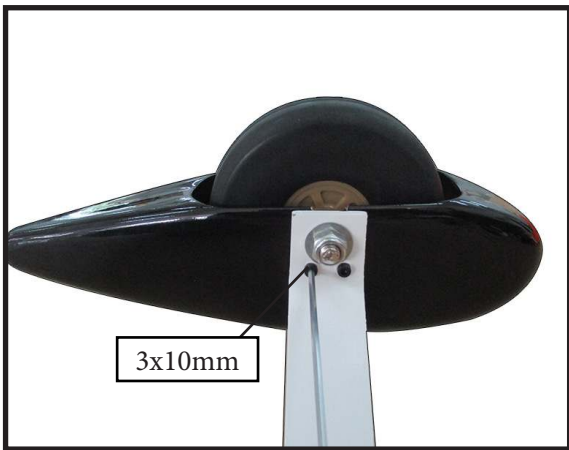

21.

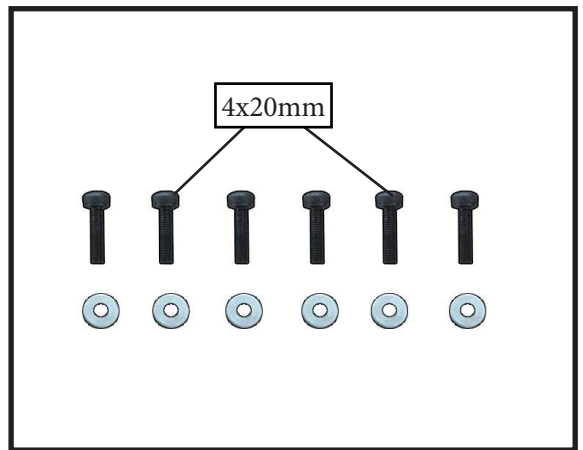

18.



22.

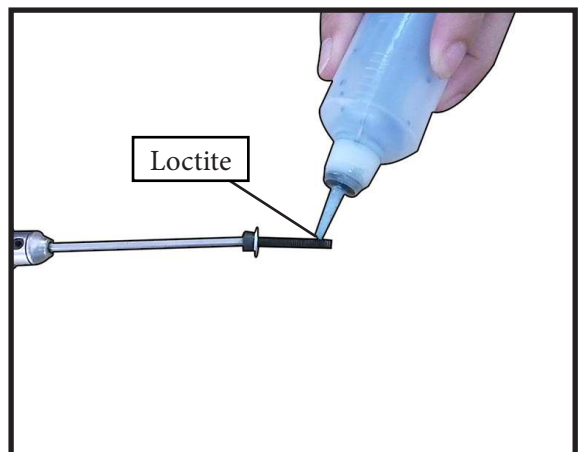

19.

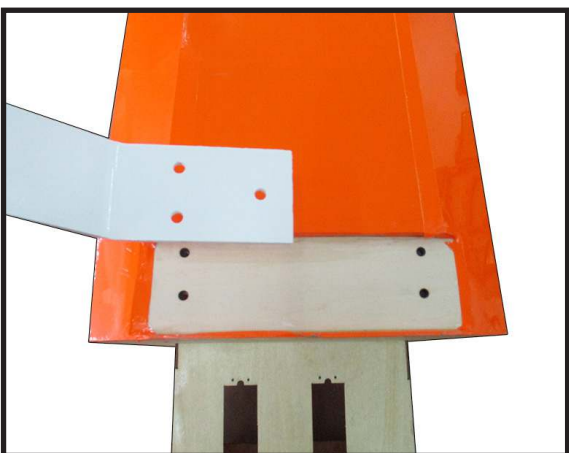

23.

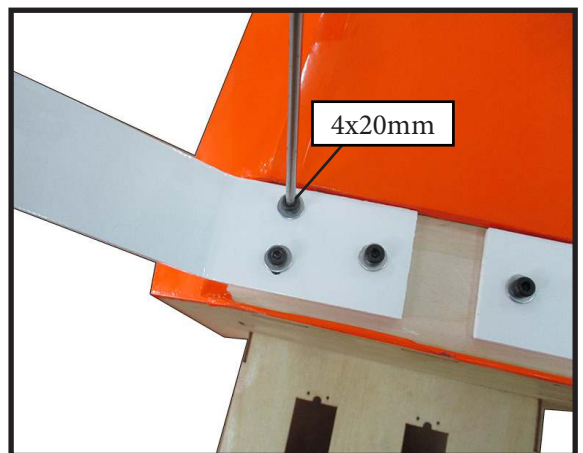

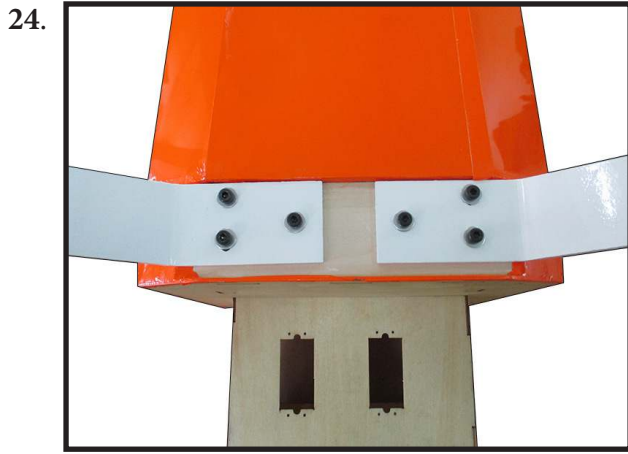

INSTALLING THE RECEIVER SWITCH

Install the switch into the precut hole in the side, in the fuselage.

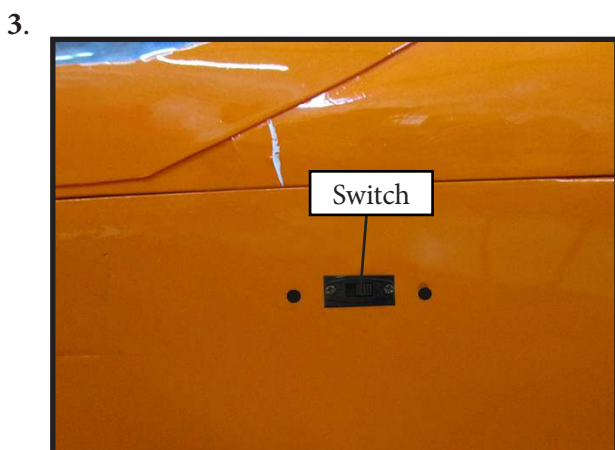
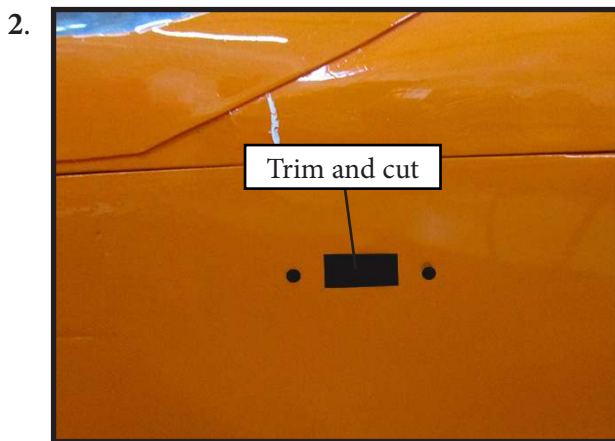

INSTALLING THE ENGINE SWITCH

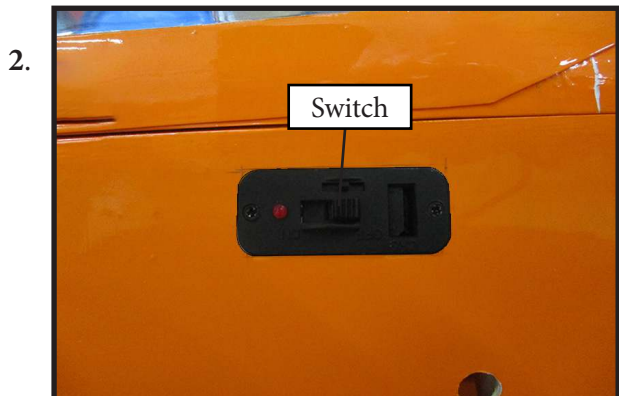

INSTALLING THE STOPPER ASSEMBLY

Using a modeling knife, carefully cut off the rear portion of one of the 3 nylon tubes leaving 1/2" protruding from the rear of the stopper. This will be the fuel pick up tube.

Using a modeling knife, cut one length of silicon fuel line. Connect one end of the line to the weighted fuel pick up and the other end to the nylon pick up tube.



2.

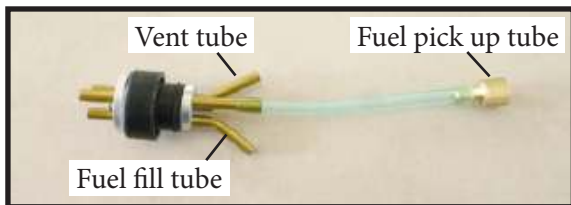

Carefully bend the second nylon tube up at a 45° angle. This tube is the vent tube.

Test fit the stopper assembly into the tank. It may be necessary to remove some of the flashing around the tank opening using a modeling knife. If flashing is present, make sure none falls into the tank.

With the stopper assembly in place, the weighted pick-up should rest away from the rear of the tank and move freely inside the tank. The top of the vent tube should rest just below the top of the tank. It should not touch the top of the tank.

When satisfied with the alignment of the stopper assembly tighten the 3 x 20mm machine screw until the rubber stopper expands and seals the tank opening. Do not overtighten the assembly as this could cause the tank to split.

FUEL TANK INSTALLATION

1.

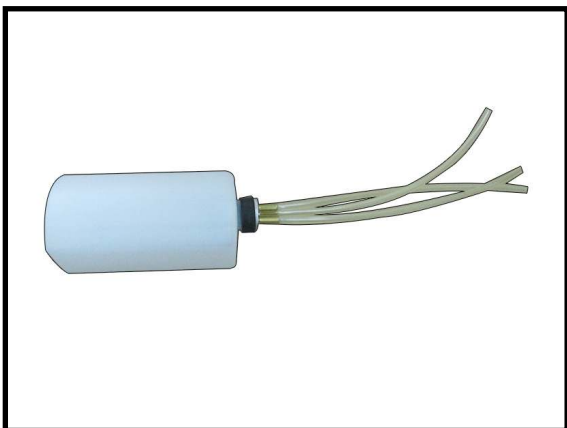

 *You should mark which tube is the vent and which is the fuel pickup when you attach fuel tubing to the tubes in the stopper. Once the tank is installed inside the fuselage, it may be difficult to determine which is which.*

Slide the fuel tank into the fuselage. Guide the lines from the tank through the hole in the firewall.

2.



3.



4.

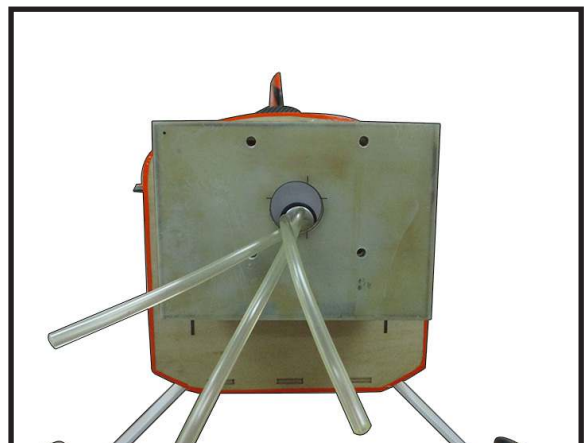

MOUNTING THE ENGINE

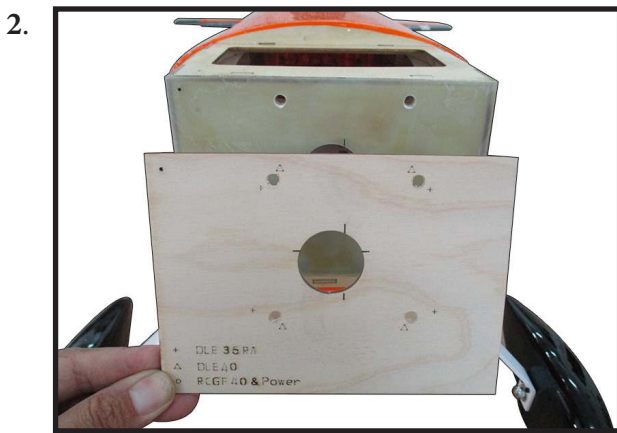
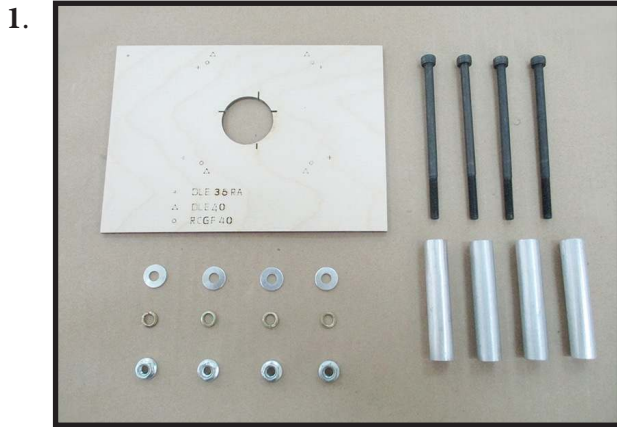

Use a 5.2mm bit to drill the engine mounting holes.

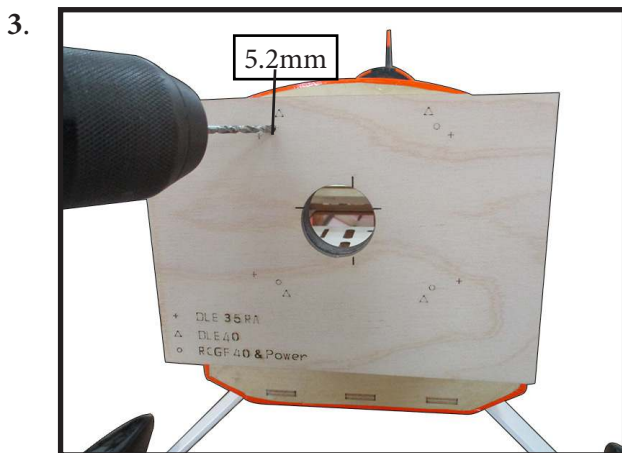

Remove mounting template from firewall. Firewall shown with mounting holes drilled ready for engine mounting.

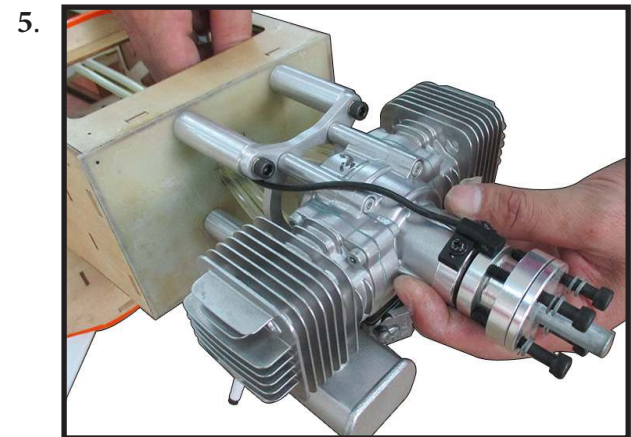
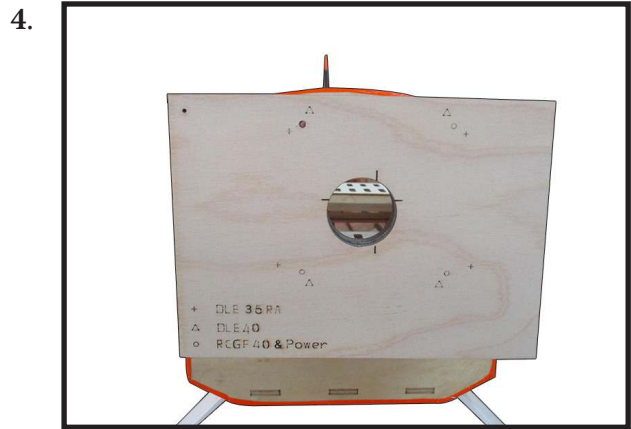

Tighten mounting bolts and secure engine to firewall.



THROTTLE SERVO INSTALLATION

1.



Use a 1/4" bit to drill a pushrod exit hole in the firewall in line with the engine carburetor throttle arm.

Assemble ball link to threaded end of pushrod.

2.

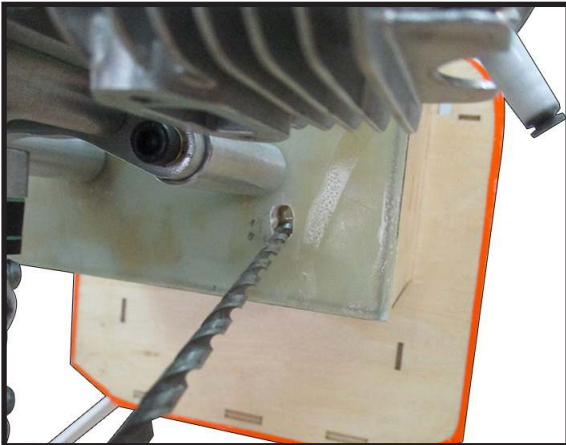

Attach throttle pushrod to the carburetor throttle arm with the ball link.

3.

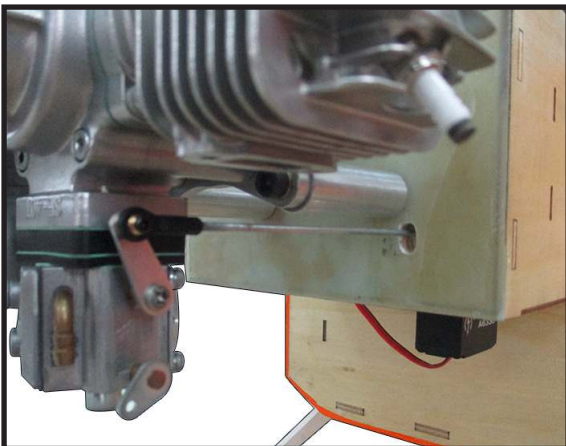

Install adjustable servo connector in the servo arm as same as picture below:

4.

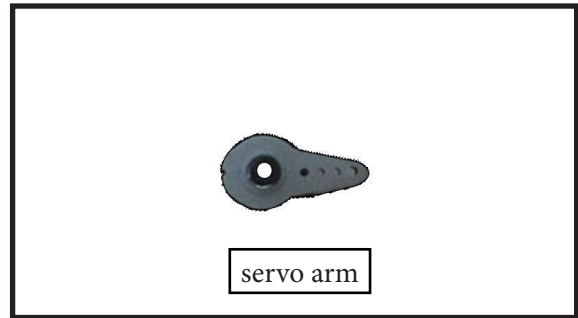

Install throttle servo into servo mounting tray

5.



Reinstall the servo horn by sliding the connector over the pushrod wire. Center the throttle stick and trim and install the servo horn perpendicular to the servo center line.

6.



Move the throttle stick to the closed position and move the carburetor to closed. Use a 2.5mm hex wrench to tighten the screw that secures the throttle pushrod wire. Make sure to use threadlock on the screw so it does not vibrate loose.

IGNITION INSTALLATION

1 Thread nylon tie through mounting holes.

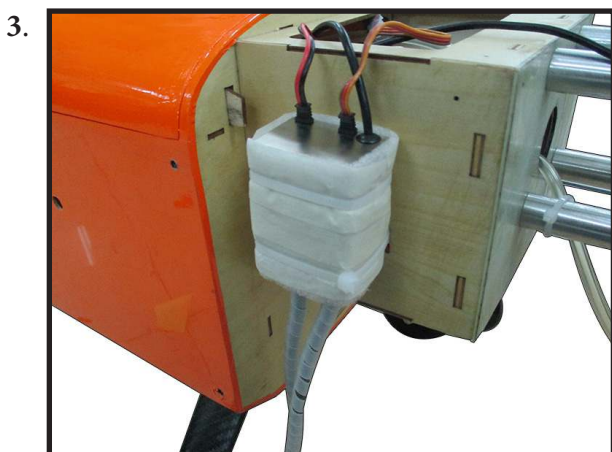
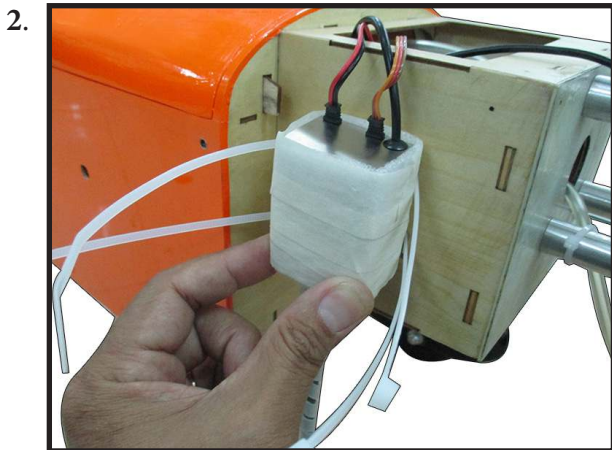
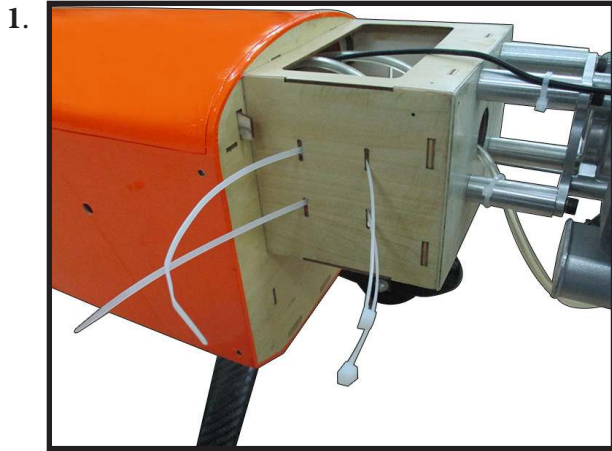

Connect ignition module to pickup line of engine. Secure with Safety Clip, safety wire, tape or other method. Ensure the plugs will not come apart from vibration or light tension.

Secure ignition wire with nylon ties as necessary.

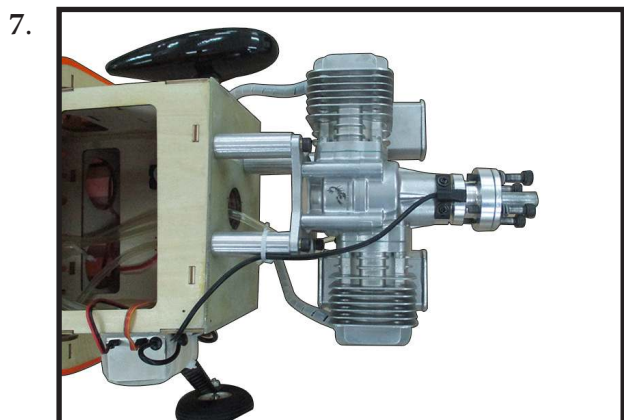
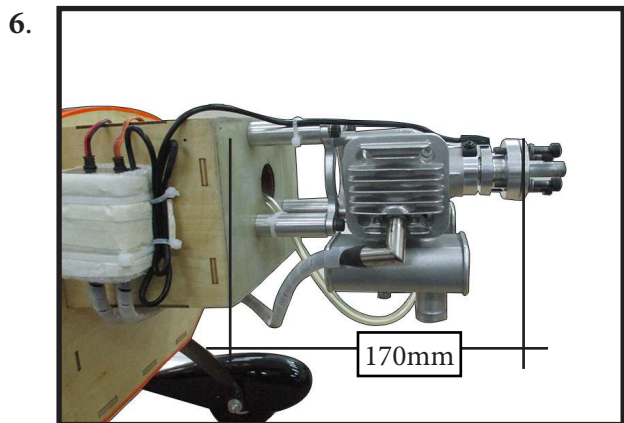
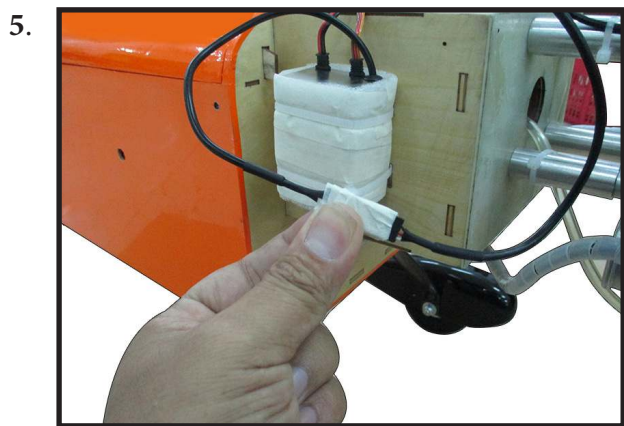
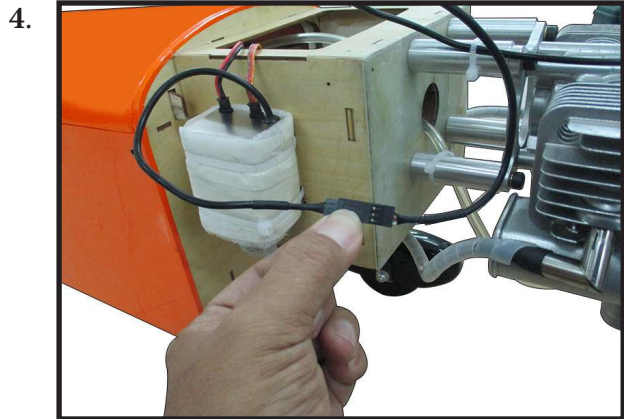

8.

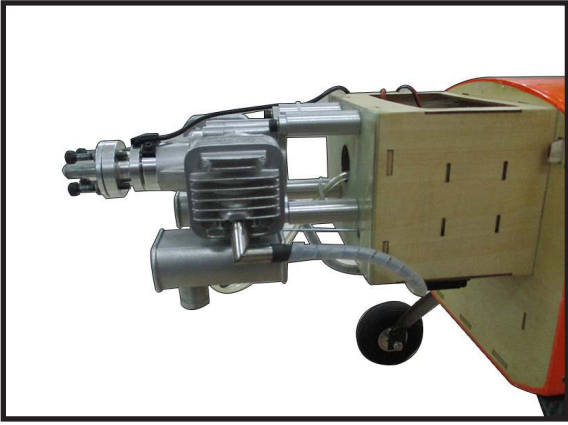

2.



9.

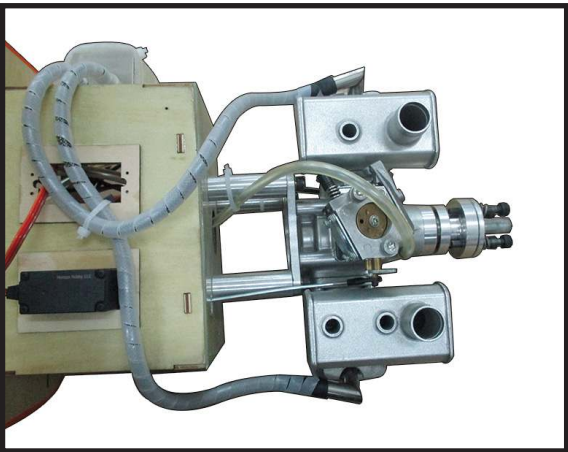

3.



COWLING

Please study images below.

1.



Tape the cowl to the fuselage using low-tack tape.

4.

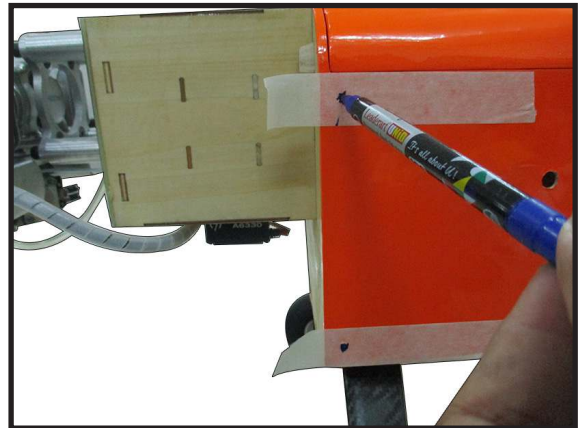

5.

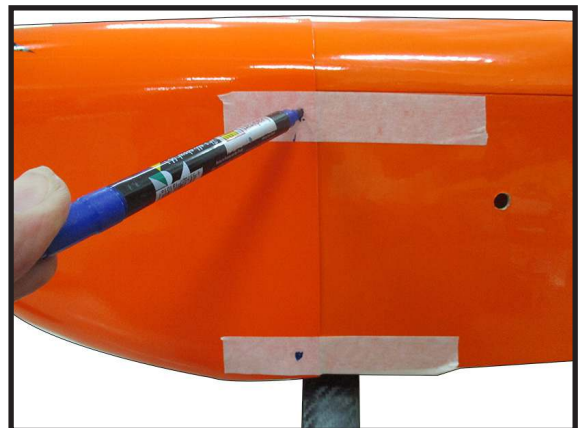

Use a drill and drill bit to drill the holes for the cowl mounting screws. Make sure the cowl position is correct before drilling each hole.

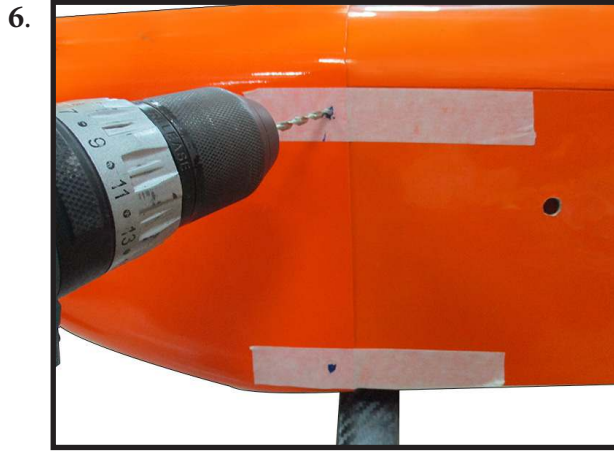

Install the muffler and muffler extension onto the engine and make the cutout in the cowl for muffler clearance. Connect the fuel and pressure lines to the carburetor, muffler and fuel filter valve. Secure the cowl to fuselage using the M3x10mm socket head screws. Putting a small length of silicon fuel tube under the head of the screw helps with vibration.

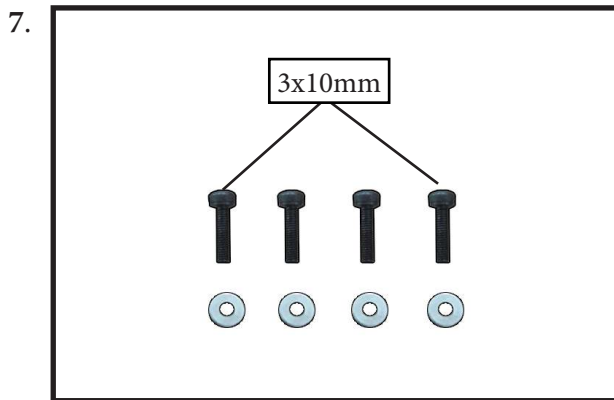

ELECTRIC POWER CONVERSION

Locate the items necessary to install the electric power conversion included with your model.

1.

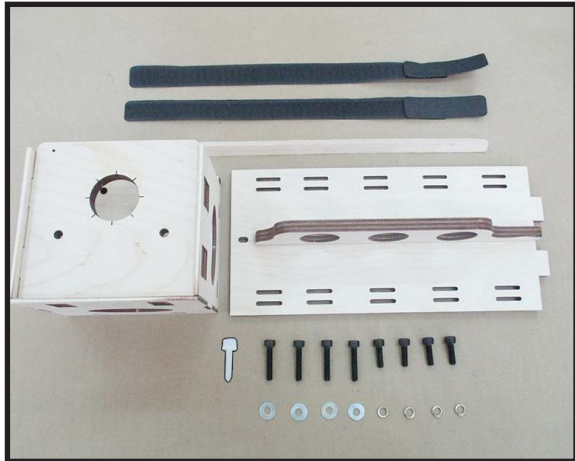

Recommend the items necessary to install the electric power conversion parts included with your model.

- Motor: 180/3000-3500 Watts

- Propeller: 20x8 ~ 21x10

- ESC: 80A - 120A

- 12S Lipo

Locate the engine mounting in position on the firewall. Use a 5mm drill bit to drill the holes necessary to mount your particular motor choice.

2.



3.



4.



5.



6.

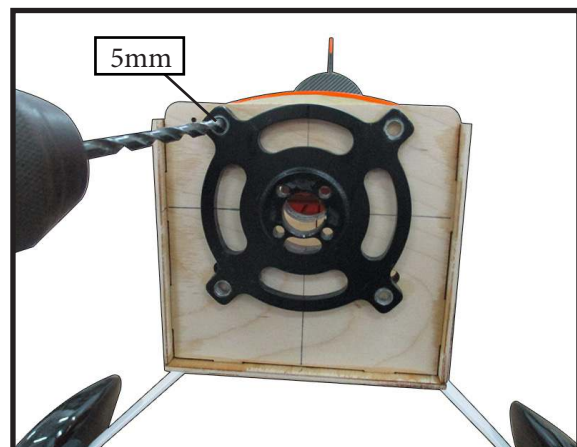

Then, use 5mm drill bit to enlarge the holes on the electric motor box.

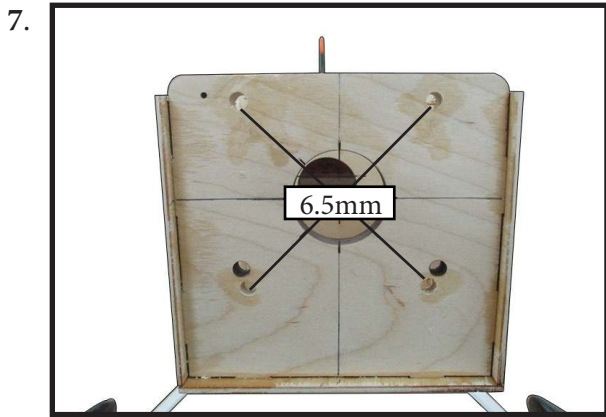

Attach the motor mount to the front of the electric motor box using four 6.5mm blind nut, four M5x25mm hex head bolts to secure the motor. Please see picture shown.

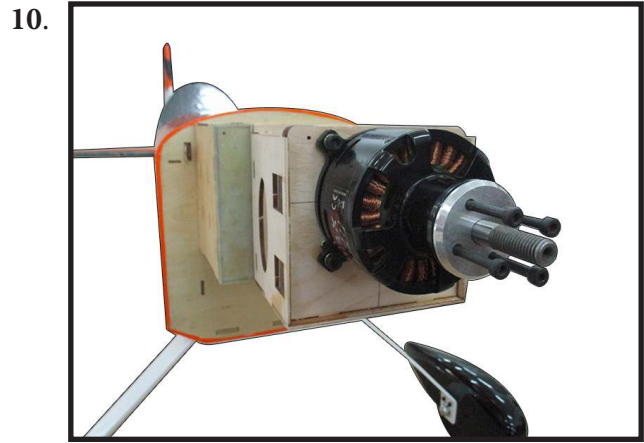
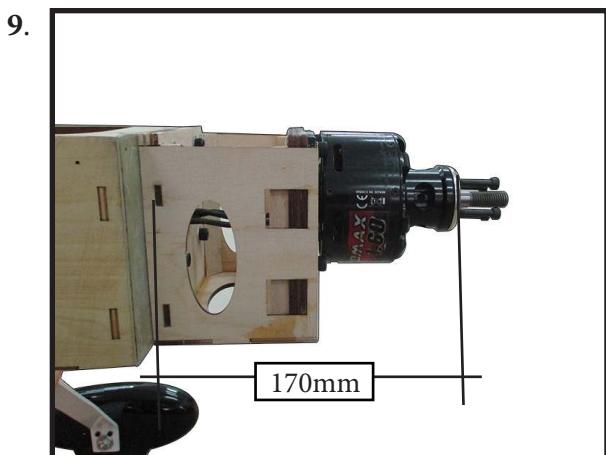
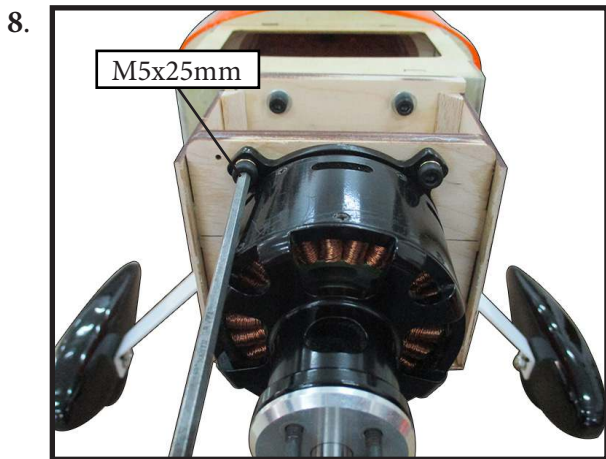

Attach the speed control to the side of the motor box using two-sided tape and tie wraps. Connect the appropriate leads from the speed control to the motor. Make sure the leads will not interfere with the operation of the motor.

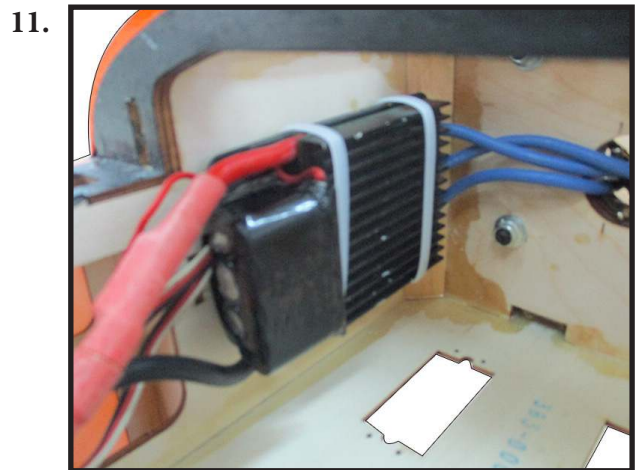

13.

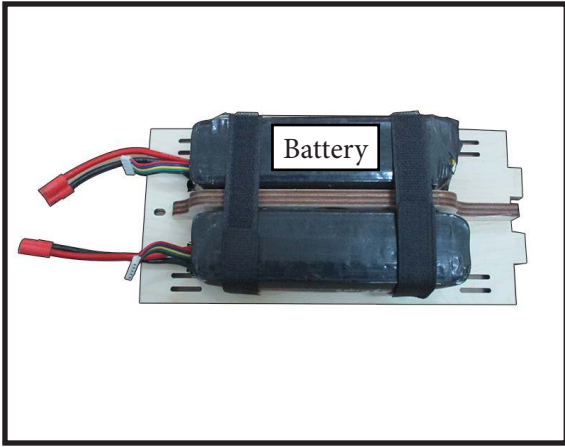

14.

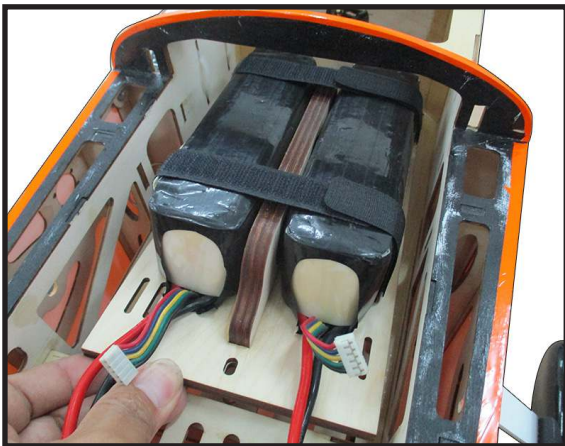

15.

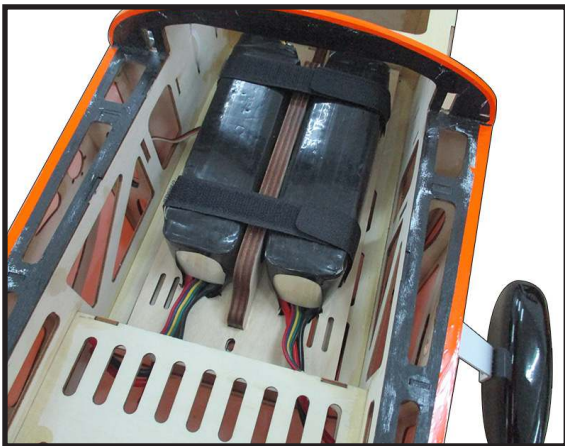

16.

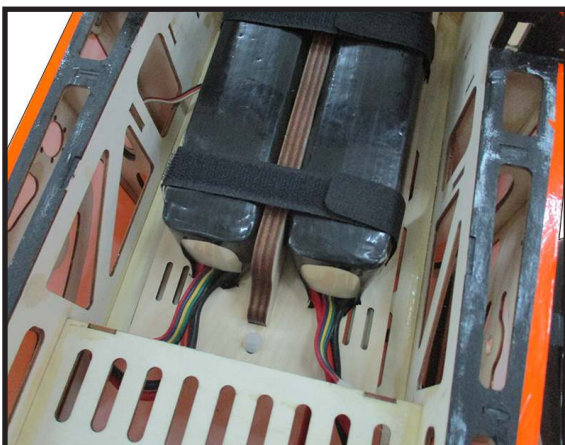

INSTALLING THE SPINNER

Install the spinner backplate, propeller and spinner cone.

1.



⚠ The propeller should not touch any part of the spinner cone. If it does, use a sharp modeling knife and carefully trim away the spinner cone where the propeller comes in contact with it.

2.



INSTALLATION PILOT AND CANOPY

Locate items necessary to install pilot and canopy.

1.



A scale pilot is included with this ARF. The Pilot included fitting well to the cockpit. (or you can order others scale pilot figures made by SG Models. They are available at SG Models distributors.)

If you are going to install a pilot figure, please use a sanding bar to sand the base of the figure so that it is flat.

Position the pilot figure on the canopy floor as show. Locate the oval shaped on the canopy floor and remove the covering. Use epoxy to glue this into the base of the pilot figure and glue the cockpit panel in place with C/A glue, please see pictures as shown.

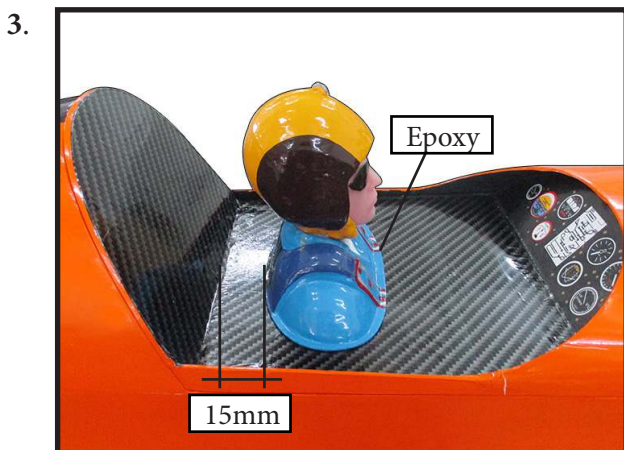

Epoxy canopy onto the fuselage. Trace around the canopy and onto the fuselage using a epoxy.



ATTACHMENT WING - FUSELAGE

Attach the aluminium tube into fuselage.

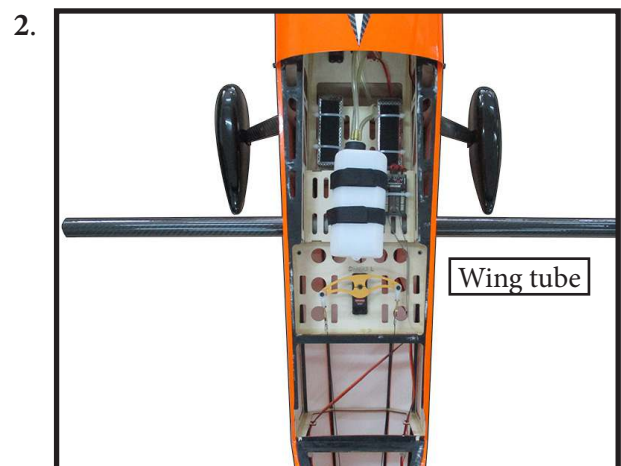
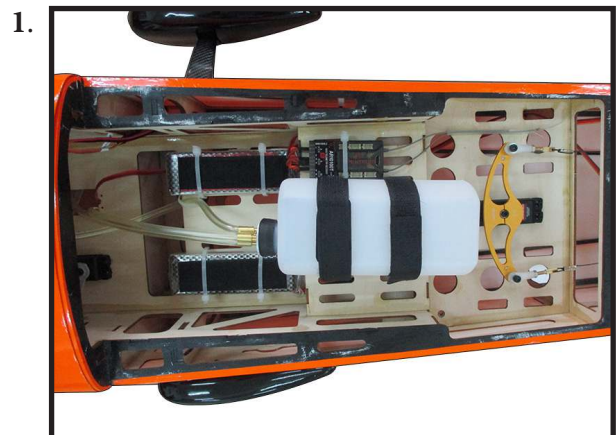

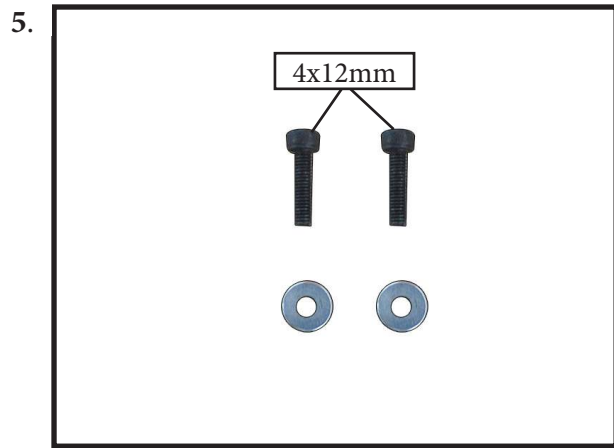
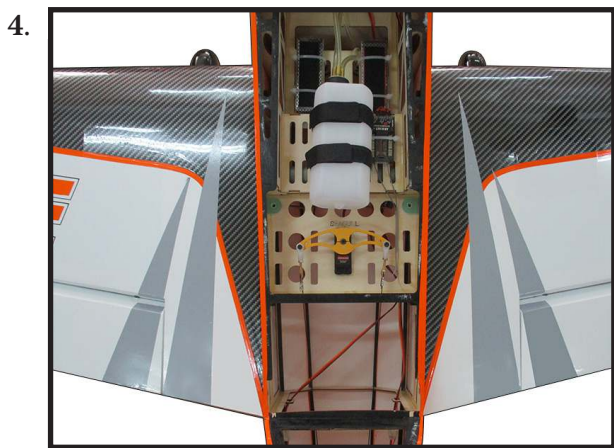
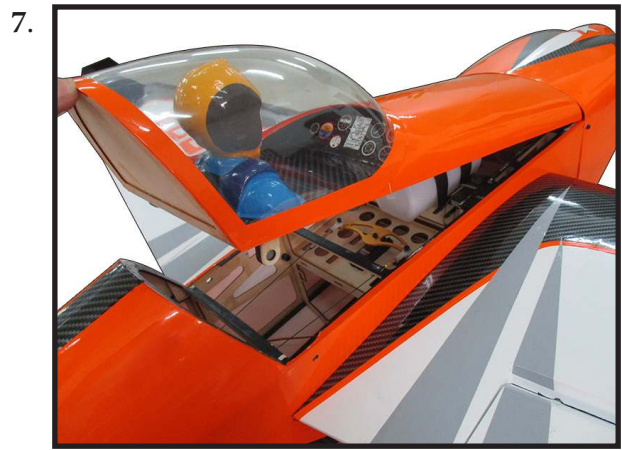
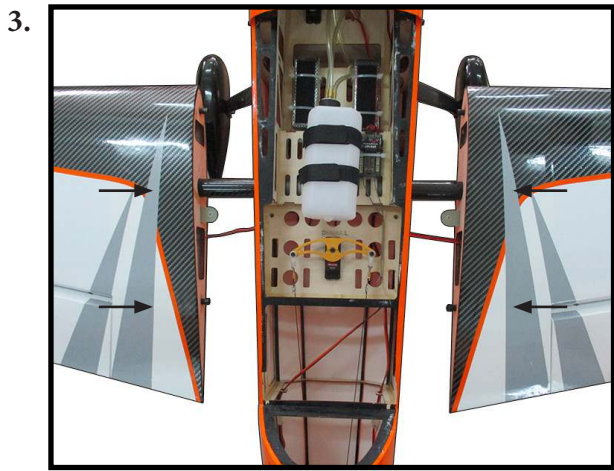

INSTALL WING TIP

Please study images below.

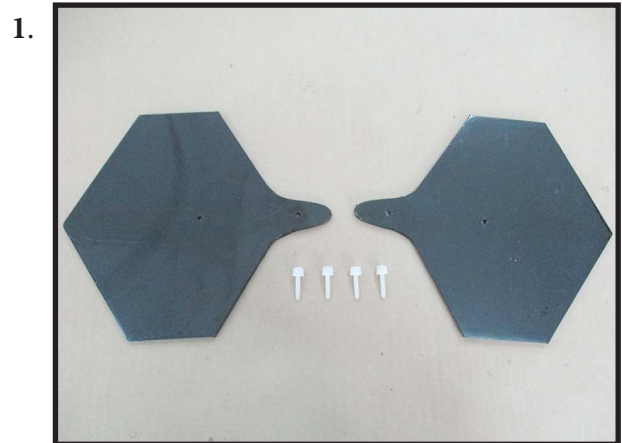



APPLY THE DECALS

If all the decals are precut and ready to stick. Please be certain the model is clean and free from oily fingerprints and dust. Position decal on the model where desired, using the photos on the box and aid in their location.

If all the decals are not precut, please use scissors or a sharp hobby knife to cut the decals from the sheet. Please be certain the model is clean and free from oily fingerprints and dust. Position decal on the model where desired, using the photos on the box and aid in their location.

BALANCING

An important part of preparing the aircraft for flight is properly balancing the model.

1) Attach the wing panels to the fuselage. Make sure to connect the leads from the aileron to the appropriate leads from the receiver. Make sure the leads are not exposed outside the fuselage before tightening the wing bolts. Your model should be flight-ready before balancing.

2) The recommended Center of Gravity (CG) location for your model is (95-110mm) back from the leading edge at the center of the wing.

3) When balancing your model, make sure it is assembled and ready for flight. Support the plane upright at the marks made on the wing with your fingers or a commercially available balancing stand. This is the correct balance point for your model.

*If possible, first attempt to balance the model by changing the position of the receiver battery and receiver. If you are unable to obtain good balance by doing so, then it will be necessary to add weight to the nose or tail to achieve the proper balance point.

With the wings attached to the fuselage, all parts of the model installed (ready to fly), and empty fuel tanks, hold the model at the marked balance point with the stabilizer level.

Lift the model. If the tail drops when you lift, the model is “tail heavy” and you must add weight* to the nose. If the nose drops, it is “nose heavy” and you must add weight* to the tail to balance.

1.

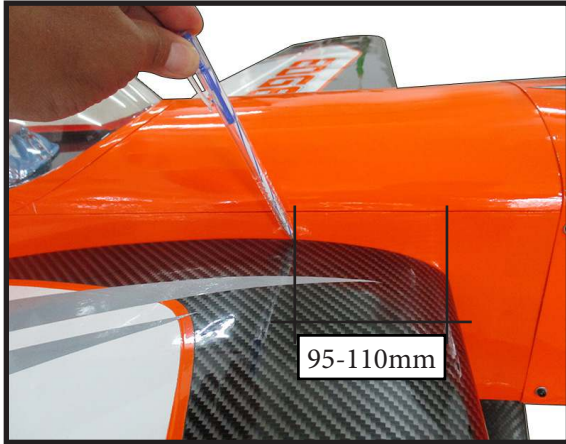

CONTROL THROWS

Ailerons:

High Rate :
 Up : 90 mm
 Down : 90 mm
 Low Rate :
 Up : 50 mm
 Down : 50 mm

Rudder:

High Rate :
 Right : 100 mm
 Left : 100 mm
 Low Rate :
 Right : 60 mm
 Left : 60 mm

Elevator:

High Rate :
 Up : 90 mm
 Down : 90 mm
 Low Rate :
 Up : 30 mm
 Down : 30 mm

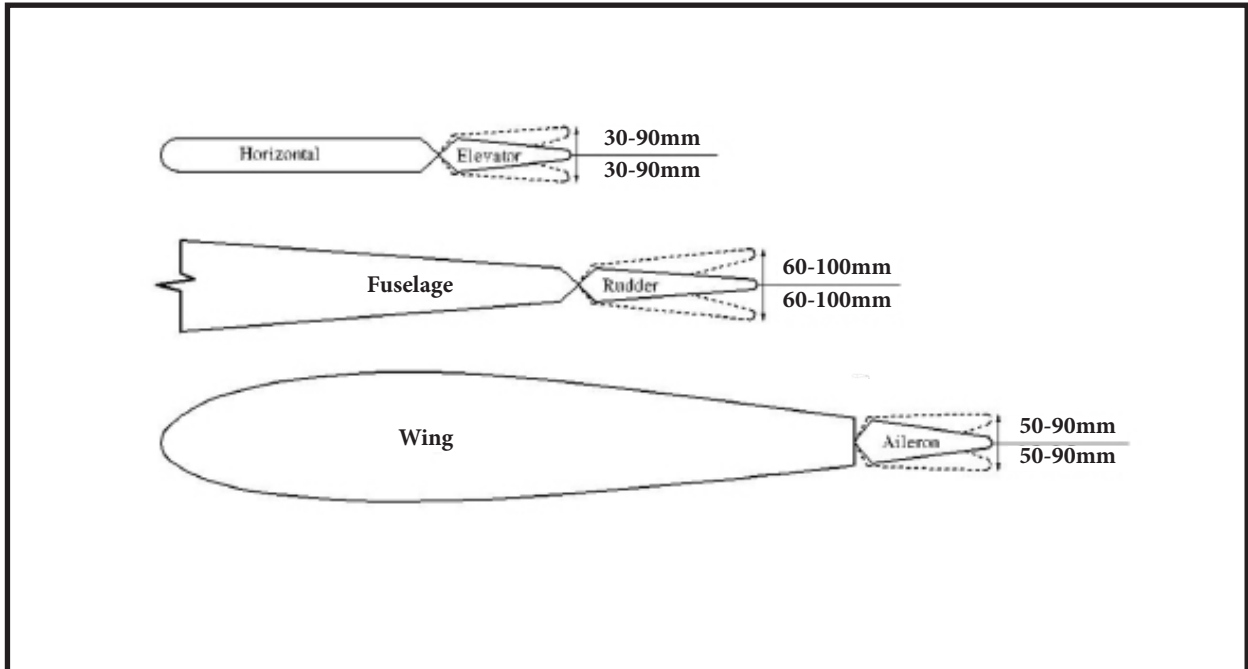

FLIGHT PREPARATION

Check the operation and direction of the elevator, rudder, ailerons and throttle.

A) Plug in your radio system per the manufacturer's instructions and turn everything on.

B) Check the elevator first. Pull back on the elevator stick. The elevator halves should move up. If they do not, flip the servo reversing switch on your transmitter to change the direction.

C) Check the rudder. Looking from behind the airplane, move the rudder stick to the right. The rudder should move to the right. If it does not, flip the servo reversing switch on your transmitter to change the direction.

D) Check the throttle. Moving the throttle stick forward should open the carburetor barrel. If it does not, flip the servo reversing switch on your transmitter to change the direction.

E) From behind the airplane, look at the aileron on the right wing half. Move the aileron stick to the right. The right aileron should move up and the other aileron should move down. If it does not, flip the servo reversing switch on your transmitter to change the direction.

PREFLIGHT CHECK

1) Completely charge your transmitter and receiver batteries before your first day of flying.

2) Check every bolt and every glue joint in the **Edge 540 V3, 77.5" wingspan 35-40cc** to ensure that everything is tight and well bonded.

3) Double check the balance of the airplane. Do this with the fuel tank empty.

4) Check the control surfaces. All should move in the correct direction and not bind in any way.

5) If your radio transmitter is equipped with dual rate switches double check that they are on the low rate setting for your first few flights.

6) Check to ensure the control surfaces are moving the proper amount for both low and high rate settings.

7) Check the receiver antenna. It should be fully extended and not coiled up inside the fuselage.

8) Properly balance the propeller. An out of balance propeller will cause excessive vibration which could lead to engine and/or airframe failure.

*We wish you many safe and enjoyable flights
with your Edge 540 V3, 77.5" wingspan 35-40cc.*

*If you have any queries, or are interested in our products,
please feel free to contact us*

Factory : 12/101A - Hamlet 4 - Le Van Khuong Street - Dong Thanh Ward -
Hoc Mon District - Ho Chi Minh City - Viet Nam.

Office : 62/8 Ngo Tat To Street - Ward 19 - Binh Thanh District - Ho Chi Minh
City - Viet Nam

Phone : 848 - 86622289 or 848- 36018777

Website : www.SeagullModels.com

Email : Sales@seagullmodels.com

Facebook : www.facebook.com/SeaGullModels.